

AF-6⁺

Compact Ring Main Unit

**AF-6⁺: our most compact substation for outdoor use.
Safe & easy to use.**

UNIVERSAL APPLICATION:

Fully compatible with IEC standards

SAFETY FIRST

- Integrated arc-killer on incomers and feeders
- Short-circuit indicators on incomers
- Compact three position load break switch
- Entire design earthed and touch-proof

ROBUST

- Concrete cable cellar
- Medium voltage cables pre-mounted and factory tested

FUNCTIONAL

- Switching operation on the top
- Easy servicing
- Manual / Remote control operation
- Straightforward synoptic diagram
- Cable test plugs for dielectric cable testing

COMPACT

- Monobloc concept, SF₆ gas insulated
- Compact three position load break switch
- Dimensions: 1100 x 600 x 1900 mm (width x depth x height)



SGC

SwitchGear Company

THE SPECIALIST IN MEDIUM VOLTAGE SWITCHGEAR

www.switchgearcompany.eu - info@switchgearcompany.eu

AF-6+ | Technical specifications

3 K / 2 KT	Unit	Ratings	
		Fuse-Switch combination	Load Break Switch
Rated Voltage	kV	12 / 17,5	12 / 17,5
Rated frequency	Hz	50 / 60	50 / 60
Rated normal current (I _r)	A	40	630
Rated short time withstand current (I _{tk})	kA	25	20
Rated short-circuit making current (I _{ma})	kA	63	50
Rated Power Frequency Withstand Voltage (U_d):			
To earth and between phases	kV	38	38
Over insulation distance	kV	45	45
Rated Lighting Impulse Withstand Voltage (U_p):			
To earth and between phases	kV	95	95
Across isolation distance	kV	110	110

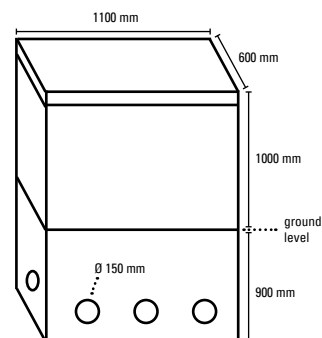

Please contact us for other configurations.



SGC stands for:

- Optimal safety for the operator
- User friendly
- IEC certified products, built to last
- Modern & ergonomic technology
- Eco-friendly production processes
- Customised options available



SGC nv

Moorstraat 24 - 9850 Nevele
Belgium

+32 (0)9 321 91 12

Internet: www.switchgearcompany.eu

E-mail: info@switchgearcompany.eu

SGC - SwitchGear Company nv.

Medium voltage switchgear, built to last.

SGC - SwitchGear Company nv has been supplying reliable products for electrical distribution for more than 35 years. Innovative ideas and environmental care are the driving forces behind SGC - SwitchGear Company nv. The development of complete solutions consists of a minimum number of components, all of which have an exceptional life span. SGC - SwitchGear Company nv stands for exceptional quality and superior customer care. Your desired specifications and deadlines are our main concern. An exclusive factory and highly automated production lines are key factors in our "state of the art" components and systems. It enables us to develop switchgear such as DF-2, DR-6/DT-6, DF-3 ,DI-2, SI-2 and DW-2 to the highest quality standards. When it comes to delivery times, prices and products SGC - SwitchGear Company nv delivers.

THE SPECIALIST IN MEDIUM VOLTAGE SWITCHGEAR