

VA-2 (RP)

CIRCUIT BREAKER



User Manual



IT IS MANDATORY TO CONSULT THIS DOCUMENT AT ALL TIMES BEFORE OPERATION

MEVOCO
MEDIUM VOLTAGE COMPONENTS

Mevoco nv – Industrielaan 33A - B-9800 Deinze - Belgium

Tel: +32 (0)9/380.30.49 - Fax: +32 (0)9/380.30.48 - e-mail: info@mevoco.be - www.mevoco.be

© 2015 Mevoco n.v.

All rights reserved.

The information provided may not be reproduced and/or published in any way or by any means (electronic or mechanical) without prior, explicit written authorisation of Mevoco nv.

The information provided is based on general data concerning the construction known at the time of publication, material qualities and working methods, so that the right to make changes is reserved.

The information given is applicable to the standard version of the circuit breaker. Therefore, Mevoco nv cannot be held liable for any damage resulting from specifications that differ from the standard version of the circuit breaker.

The available information has been assembled with the greatest possible care, but Mevoco nv cannot be held liable for any mistakes in the information or the consequences thereof.

In accordance with the legislation concerning the protection of trademarks, the user names, trade names, trademarks, etc. used by Mevoco nv cannot be considered to be free.

CONTENTS

INHOUDSOPGAVE	iii
VOORWOORD	vii
DIT DOCUMENT	vii
PICTOGRAMMEN IN DE DOCUMENTATIE	vii
VERWANTE DOCUMENTATIE	ix
SERVICE EN TECHNISCHE ONDERSTEUNING	ix
IDENTIFICATIE VAN DE VERMOGENSCHAKELAAR	ix
ALGEMENE VEILIGHEIDSVORSCHRIFTEN EN –INSTRUCTIES	x
GEBRUIK VOLGENS BESTEMMING	xi
1 ALGEMENE BESCHRIJVING	1-1
1.1 WERKINGSPRINCIPE VERMOGENSCHAKELAAR VA-2	1-2
1.1.1 VACUÛMONDERBREKER	1-2
1.1.2 AANDRIJVING	1-3
1.1.2.1 Energieopslag	1-3
1.1.2.2 Sluiten van de contacten	1-3
1.1.2.3 Openen van de contacten	1-4
2 TECHNISCHE SPECIFICATIES	2-1
2.1 VERMOGENSCHAKELAAR VA-2	2-1
2.2 DIGITAAL BEVEILIGINGSRELAIS RP600	2-2
2.2.1 BESCHIKBARE TYPEN VERMOGENSCHAKELAARS	2-2
2.3 AFMETINGEN EN GEWICHTEN VERMOGENSCHAKELAAR VA–2	2-3
2.4 AFMETINGEN EN GEWICHTEN DIGITAAL BEVEILIGINGSRELAIS RP600	2-4
2.5 LEVERBARE OPTIES VOOR DE AANDRIJVING	2-5
3 TRANSPORT EN OPSLAG	3-1
3.1 VEILIGHEIDSVORSCHRIFTEN – TRANSPORT	3-1
3.2 VEILIGHEIDSVORSCHRIFTEN – OPSLAG	3-2
4 INSTALLATIE	4-1
4.1 VEILIGHEIDSVORSCHRIFTEN – INSTALLATIE	4-1
4.1.1 ALGEMEEN	4-1
4.1.2 AANBEVELINGEN - OPSTELLINGSRUIMTE	4-1
4.1.2.1 Vloeroppervlakte	4-1
4.1.2.2 Omgevingscondities	4-1
4.1.2.3 Ventilatie	4-2
4.2 UITPAKKEN	4-2

4.3 MONTAGE	4-3
4.3.1 AARDING VAN DE VERMOGENSCHAKELAAR	4-3
5 GEBRUIK	5-1
5.1 VEILIGHEIDSVOORSCHRIFTEN – GEBRUIK	5-1
5.2 BEDIENING VERMOGENSCHAKELAAR VA-2	5-1
5.2.1 INSCHAKELEN VERMOGENSCHAKELAAR	5-2
5.2.2 UITSCHAKELEN VERMOGENSCHAKELAAR	5-2
5.2.3 OPSPANNEN VAN DE DRUKVEER	5-3
5.3 BEDIENING DIGITAAL BEVEILIGINGSRELAIS RP600	5-3
5.3.1 STRUCTURE DU MENU	5-5
5.3.2 PROGRAMMERING VAN DE RP600	5-6
5.3.2.1 Programmering via lokaal bedieningspaneel	5-6
5.3.2.1.1 Configureren van fout relais R1 en R2	5-7
5.3.2.1.2 Configureren ingang IN1	5-8
5.3.2.1.3 Instellen taal bedieningspaneel	5-8
5.3.2.1.4 Instellen stroomverhouding	5-8
5.3.2.1.5 Instellen parameters	5-9
5.3.2.2 Programmering met behulp van RP600 software	5-10
5.3.2.2.1 Data	5-11
5.3.2.2.2 Algemeen	5-12
5.3.2.2.3 Lijn	5-12
5.3.2.2.4 Aarde	5-12
5.3.2.2.5 Uitschakelkarakteristieken	5-12
5.3.3 UITLEZEN STROOMWAARDEN	5-13
5.3.4 UITLEZEN VAN STORINGSINFORMATIE	5-13
5.3.4.1 Storingsinformatie via de LED indicators	5-14
5.3.4.2 Storingsinformatie via de display	5-14
5.3.4.2.1 Uitlezen storinggeheugen	5-15
6 ONDERHOUD	6-1
6.1 VEILIGHEIDSVOORSCHRIFTEN - ONDERHOUD	6-1
6.2 ONDERHOUD – ALGEMEEN	6-1
6.2.1 ALGEMENE CONTROLEWERKZAAMHEDEN	6-2
6.2.2 REINIGEN VAN DE VERMOGENSCHAKELAAR	6-2
7 AANSLUITSCHEMA'S	7-1
7.1 NUMMERING KLEMMENRIJ	7-1
7.2 AANSLUITSCHEMA DIGITAAL BEVEILIGINGSRELAIS RP600	7-2
7.3 STROOMWAARDE STROOMTRANSFORMATOREN (VA-2RP) SELECTEREN	7-3
8 VERMOGENSCHAKELAARS EN HET MILIEU	8-1
8.1 VERPAKKINGSMATERIAAL	8-1
8.2 AFDANKEN VAN DE VERMOGENSCHAKELAAR	8-1

9 MONTAGE VAN OPTIES	9-1
9.1 INSCHAKELSPOEL	9-1
9.1.1 VOORBEREIDING TEN BEHOEVE VAN DE MONTAGE	9-1
9.1.2 MONTAGE VAN DE INSCHAKELSPOEL – ALGEMEEN	9-2
9.1.2.1 Montagevoorschrift	9-3
9.1.2.1.1 Elektrische controle met externe stroombron	9-3
9.1.3 EINDCONTROLE EN INBEDRIJFSTELLING	9-3
9.2 UITSCHAKELSPOEL(EN)	9-4
9.2.1 VOORBEREIDING TEN BEHOEVE VAN DE MONTAGE	9-4
9.2.2 MONTAGE VAN DE UITSCHAKELSPOEL(EN) – ALGEMEEN	9-4
9.2.2.1 Montagevoorschrift	9-5
9.2.2.1.1 Elektrische controle met externe stroombron	9-6
9.2.3 EINDCONTROLE EN INBEDRIJFSTELLING	9-6
9.3 PLAATSEN VAN EEN MOTOR	9-6
9.3.1 VOORBEREIDING TEN BEHOEVE VAN DE MONTAGE	9-6
9.3.2 MONTAGE VAN DE MOTOR – ALGEMEEN	9-7
9.3.3 MONTAGEVOORSCHRIFT	9-8
9.3.4 EINDCONTROLE EN INBEDRIJFSTELLING	9-9
9.4 MINIMASPOEL	9-9
9.4.1 VOORBEREIDING TEN BEHOEVE VAN DE MONTAGE	9-9
9.4.2 MONTAGE VAN DE MINIMASPOEL ALGEMEEN	9-9
9.4.3 MONTAGEVOORSCHRIFT	9-12
9.4.4 MONTAGE-KIT BASISPLAAT	9-13
9.4.5 MONTAGEVOORSCHRIFT VOOR DE BASISSTEUN	9-14
9.4.6 EINDCONTROLE EN INBEDRIJFSTELLING	9-14
9.5 SLEUTELVERGREDELINGEN	9-14
9.5.1 VOORBEREIDING TEN BEHOEVE VAN DE MONTAGE	9-14
9.5.2 MONTAGE VAN DE SLEUTELVERGREDELING – ALGEMEEN	9-15
9.5.3 MONTAGEVOORSCHRIFT VOOR DE BASISSTEUN:	9-16
9.5.4 EINDCONTROLE EN INBEDRIJFSTELLING	9-16
9.6 HULPCONTACTEN	9-17
9.6.1 VOORBEREIDING TEN BEHOEVE VAN DE MONTAGE	9-17
9.6.2 MONTAGE VAN DE HULPCONTACTEN – ALGEMEEN	9-17
9.6.3 MONTAGE VAN DE HULPCONTACTEN MONTAGEKIT	9-18
9.6.4 MONTAGEVOORSCHRIFT VOOR DE BASISSTEUN	9-18
9.6.5 EINDCONTROLE EN INBEDRIJFSTELLING	9-19
9.6.6 MONTAGE INSTRUCTIES VOOR HULPCONTACTEN GEWAPENDE VEER	9-19
9.6.7 EINDCONTROLE EN INBEDRIJFSTELLING	9-19

PREFACE

This document

This document is intended as a reference with which operators can safely and economically transport, install, use and maintain the circuit breaker. At all places where the word 'circuit breaker' is mentioned in this document, this refers to the circuit breaker VA-2 with the optional digital protection relay RP600. All cases involving specific information with respect to the digital protection relay RP600 (optional) are indicated as such. Therefore this document applies to the types of circuit breakers given below:

- VA-2: Circuit breaker
- VA-2RP: Circuit breaker + digital protection relay RP600

The chapters and sections are numbered. The page numbering (consisting of the chapter number and the page number) and the document code can be found at the bottom of each page.

Pictograms in the documentation

The following pictograms are used in the user's manual of the circuit breaker:



CAUTION

Procedures that - when not carried out with due care - can result in damage to the circuit breaker, the surrounding area or the environment.



WARNING

Danger of high voltage



Notes, suggestions and advices

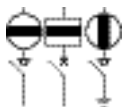

Open the load-break switch as well as the circuit breaker and close the earthing switch before carrying out the work described.



Consult the indicated information sources first.



Protect the circuit breaker from water or damp.



Ensure reuse or environment-friendly processing of the materials used.

Related documentation

The following related technical documentation is available for the circuit breaker:

- Circuit breaker brochure.
- Digital protection relay RP600 brochure.
- User's manual for digital protection relay RP600.

Service and technical support

For information concerning specific settings, maintenance or repair work that is not mentioned here, please contact Mevoco N.V.

In this case always mention the following data of the circuit breaker:

- type of circuit breaker
- rated voltage circuit breaker
- rated current circuit breaker
- trip power of circuit breaker
- serial number of circuit breaker
- serial number of digital protection relay

See "Identification of the circuit breaker".

Identification of the circuit breaker

Each circuit breaker is fitted with a type plate (fig. 0.01) and a stamped serial number (fig. 0.02).

Identification plate (fig. 001)

- A IEC standard
- B Type of circuit breaker
- C Specifications

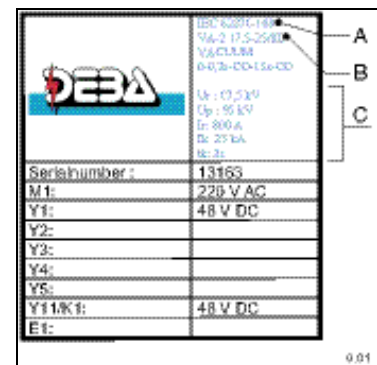

Serial number (fig. 002)

- A Serial number

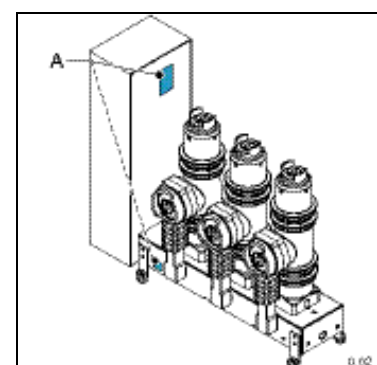

General safety directions and instructions

Mevoco n.v. does not accept any liability for damage or injury caused by not (strictly) following the safety regulations and instructions, or by negligence during the installation, use, maintenance or repair of the circuit breaker and any accompanying options.

Depending on the specific circumstances of use or options applied, extra safety instructions may be necessary. Please contact Mevoco n.v. immediately if you encounter a potential danger when using the circuit breaker.

The operator/owner of the circuit breaker is fully responsible at all times for following the locally applicable safety regulations and guidelines.

User Manual

- Everyone using or operating the circuit breaker must know the contents of the user's manual and very closely follow the directions contained in it. The operator/owner must instruct the users in accordance with the user's manual and observe all directions and instructions.
- Never change the order of the activities to be carried out.
- Always keep the user's manual in the vicinity of the circuit breaker.

Pictograms and safety symbols

Pictograms, symbols and instructions on the circuit breaker are part of the safety provisions. Therefore, they may not be covered or removed and must be present and clearly legible throughout the entire lifetime of the circuit breaker.

- Replace or repair illegible or damaged pictograms, symbols and instructions immediately. For this purpose contact Mevoco n.v.

Technical specifications

- The technical specifications may not be changed.
- Modification of (parts of) the circuit breaker is not permitted.

Transport, storage, installation, use and maintenance

- See:
 - "Safety regulations – transport"
 - "Safety regulations – storage"
 - "Safety regulations – installation"
 - "Safety regulations – use"
 - "Safety instructions – maintenance"

Intended use

The circuit breaker has been exclusively designed for protection of distribution and dispersion switchgear, transformers, generators and electric motors so as to enable the circuit breaker to safely break or switch off the (normal) operating current as well as a fault current (current that occurs at a fault, thermal overload or short circuit) in conformity with the specifications and conditions provided by Mevoco n.v. Any other or further use is not considered to be in accordance with the intended use.¹

Mevoco n.v. accepts no liability for any damage or injury resulting from such unauthorised use.

The circuit breaker complies with the applicable standards and guidelines. See the Technical Brochure.

Only use the circuit breaker in a technically perfect condition in accordance with the intended use described above..



Keep sealed connections intact at all times. Breaking the sealed connections irrevocably voids any claims under guarantee.

¹ "Intended use" as laid down in EN 292-1 is "...the use for which the technical product is suited as specified by the manufacturer-including his directions in the sales brochure." In case of doubt it is the use that can be deduced from the construction, the model and the function of the technical product that is considered normal use. Operating the product within the limits of its intended use also involves observing the instructions in the user manual.

1 GENERAL DESCRIPTION

The vacuum circuit breakers of Mevoco n.v. have been designed in a user- and maintenance-friendly way for protection of distribution and dispersion switchgear, transformers, generators and electrical motors. The circuit breakers can safely break or switch off the (normal) operating current as well as a fault current (current that occurs at a fault, thermal overload or short circuit). All circuit breakers can easily be installed and maintained.

In order to increase the performances and to make the operating conditions even safer, the circuit breakers can be provided with high-quality communication and measuring functions by applying the optional digital protection relay RP600.

For a complete description of the working principle of the circuit breaker:

- See: "Operating principle of the circuit breaker VA-2"
- See: "Operating principle digital protection relay RP600"

All circuit breakers of the VA-2 type also fit in the modular concept of DF-2 switchgears from SGC - Switchgear Company n.v.

The circuit breaker consists of the following main components:

- A Mechanical drive
- B Poles L1, L2 and L3
- C Chassis (supporting structure)
- D Runner (wheels)
- E Digital protection relay RP600 (optional)
- F Current transformers L1, L2 and L3 (optional)

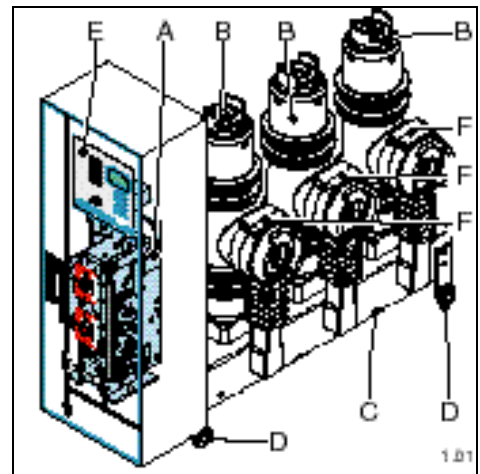

1.1 Operating principle of the circuit breaker VA-2

1.1.1 Vacuum interrupter (VI)

De vermogenschakelaar bestaat uit drie polen. Elke pool is verantwoordelijk voor het in- en uitschakelen van één van de drie fasen van het te schakelen elektrische vermogen. In het hart van elke pool is daartoe een vacuümonderbreker voorzien.

The vacuum interrupter consists of two contacts, one fixed contact (A) and a one moving (B), forming the breaker camber. The contacts are placed in an hermetically sealed ceramic enclosure (C). Due to the moving contact, the interrupter can be opened and closed. Opening and closing of the interrupter is done by means of a mechanical drive (see 'Mechanical drive').

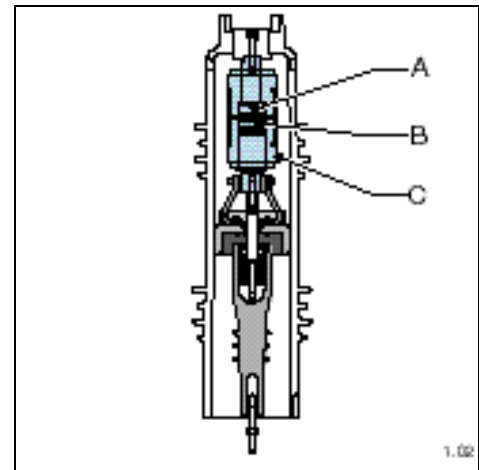

The opening of the contacts (separation of the moving contacts from the fixed contact) provokes an arc. This arc consists of ions and electrons originated from the Cu/Cr metal alloy of the contacts. At the moment that the distance between the two contacts is large enough to make the current zero and the transient current comes up again, the arc will disappear. The special geometry of the contacts has been chosen in such a way, that the current can be switched off quickly and safely, thus restoring the vacuum.

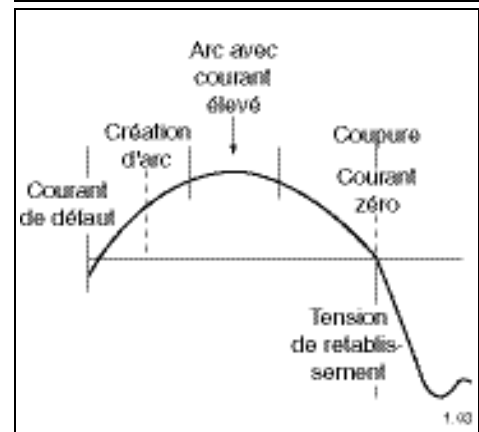

Boogvlam en onderbrekingsfenomeen in vacuüm

1.1.2 Mechanical drive

The mechanical drive is of the CRR type (spring drive with reclosing). This is a mechanism in which the energy for opening and closing the contact is stored in a compression spring. Application of the mechanism allows quick succession of opening and closing cycles.

The compression spring, in which the energy is stored, is at the one end connected with the compression mechanism (A) and at the other end with the main mechanical drive shaft (B). The rotating movement of the main shaft simultaneously drives the three mobile contacts in the three poles through a transmission link (C). Thus the three interrupters can synchronically be opened and closed.

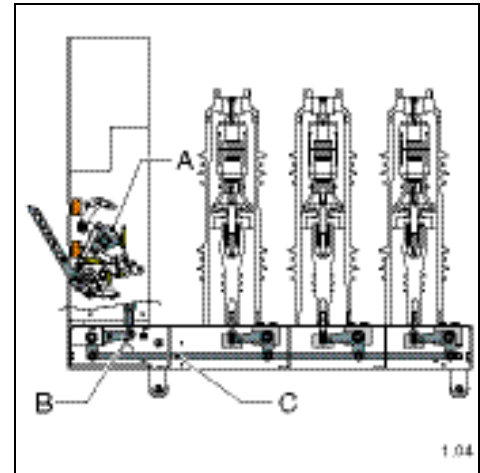

1.1.2.1 Energy storage

By compressing the spring energy can be stored for a closing and opening cycle. The compression spring can be tensioned in two ways:

- Manually by using the handle that can be pulled out (A).
- Automatically through an optional electric motor.

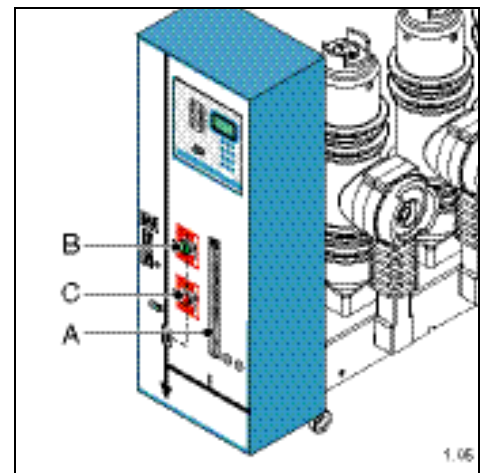

1.1.2.2 Closing the contacts

Only after the compression spring has been tensioned, the contacts of the vacuum interrupter can be closed. The closing of the contacts or the closing on of the circuit breaker can be done in two ways:

- Manually by pressing the switching-on button (fig. 1.05B).
- Automatically by sending an electric pulse to the shunt-closing coil.

After the closing of the contacts they are locked in the 'closed' position.

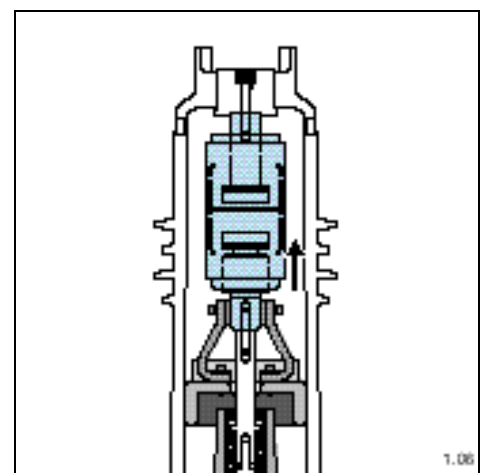

After closing of the contacts the tensioning transmission is released again, allowing manual retensioning of the compression spring. In case automatic tensioning is applied, the electric motor will be automatically switched on after closing of the contacts, automatically compressing the spring (in less than 15 seconds). If the compression spring is tensioned before the circuit breaker is opened, the circuit breaker is ready for an operating cycle of O – 0.3 s – CO. If automatic tensioning is applied, the spring will be compressed in less than 15 seconds, an operating cycle of O – 0,3 s – CO – 15 s – CO is possible.

1.1.2.3 Opening the contacts

The residual energy that is left in the compression spring when the compression spring is relaxed and the contacts are closed can open the contacts again.

The opening of the contacts or the switching off of the circuit breaker can be done in a number of ways:

- Manually by pressing the switching-off button (fig. 1.05C).
- Automatically by sending an electric pulse to the first or second shunt-trip coil.
- Automatically by zero voltage with the time delayed undervoltage trip coil (option delayed).
- Automatically when there is a fault current (current that occurs at a fault, thermal overload or short circuit) by application of the digital protection relay RP600 (see AG614102).

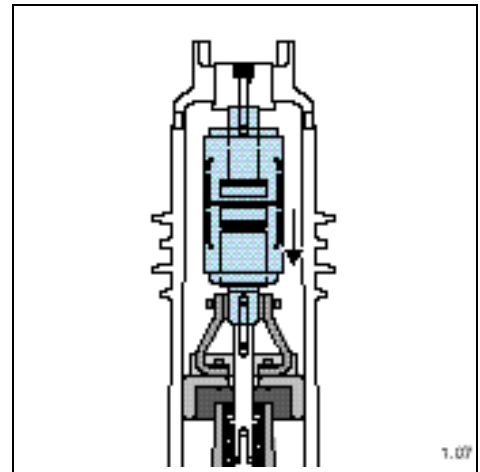

When opening the circuit breaker the contacts are locked in the 'open' position.

2 TECHNICAL SPECIFICATIONS

2.1 Circuit breaker VA-2

Specified item	Unit	400A	630A	800A	1,250A
Standards applied					
Rated voltage Un	kV	12 - 17.5 - 24	12 - 17.5 - 24	12 - 17.5 - 24	12 - 17.5
Rated withstand voltage at $f_n/1\text{min.}$	kV	28 - 38 - 50	28 - 38 - 50	28 - 38 - 50	28 - 38
Rated impulse withstand voltage 1.2/50 μs	kV	75 - 95 - 125	75 - 95 - 125	75 - 95 - 125	75 - 95
Rated frequency	Hz	50/60	50/60	50/60	50/60
Rated current	A	400	630	800	1250
Rated short duration current	kA	12.5 - 20 - 25	12.5 - 20 - 25	12.5 - 20 - 25	12.5 - 20 - 25
Duration of rated short circuit	s	3	3	3	3
Rated limit peak current	kA	31.5 - 50 - 63	31.5 - 50 - 63	31.5 - 50 - 63	31.5 - 50 - 63
Rated breaking capacity at $\leq U_n$	kA	12.5 - 20 - 25	12.5 - 20 - 25	12.5 - 20 - 25	12.5 - 20 - 25
DC component	%	36	36	36	36
Making current	kA	31.5 - 50 - 63	31.5 - 50 - 63	31.5 - 50 - 63	31.5 - 50 - 63
Switching order		O – 0.3s – CO – 15s – CO			
Rated breaking capacity at single connected cond. battery at Un and $f_n = 50[\text{Hz}]$	A	400	400	400	400
Overvoltage factor		< 2.5	< 2.5	< 2.5	< 2.5
Rated breaking capacity at unloaded cable	A	25	25	25	25
Overvoltage factor	%	< 4	< 4	< 4	< 4
Rated breaking capacity at unloaded transformer	A	12.5	12.5	12.5	12.5
Overvoltage factor		< 4	< 4	< 4	< 4
Rated closing time	ms	50	50	50	50
Rated opening time	ms	42	42	42	42
Rated breaking time	ms	60	60	60	60
Mechanical lifetime in number of CO switches of the contacts		30,000	30,000	30,000	30,000
Lifetime of the vacuum interrupter	years	30	30	30	30
Electrical lifetime in number of CO switches		10,000	10,000	10,000	10,000
Weight	kg	113	116	116	120

2.2 Digital protection relay RP600

Specified item	Value
Interference suppression	According to: IEC – EN 61000-4-2/3 (level 3) IEC – EN 61000-4-4/5/6/12
Emission	<ul style="list-style-type: none"> • Casing 30 MHz – 230 MHz, 40 dB(μV/m) quasi peak at 10 m. • Casing 230 MHz – 1000 MHz, 47 dB(μV/m) quasi peak at 10 m. • Power supply voltage 0.15 MHz – 0.50 MHz, 79 dB(μV) quasi peak, 66 dB(μV) average. • 3Power supply voltage 0.50 MHz – 30 MHz, 73 dB(μV) quasi peak, 60 dB(μV) average.
Ambient temperature	-10 °C – 55 °C
Storage temperature	-20 °C – 60 °C
Relative air humidity	According to CEI 68-2-30
Measurement inputs (L1/L2/L3)	$I_{Nom} = 1A, I_{Max} = 3 \times I_{Nom}$
Signal input (IN1)	12 VDC ± 10%
Output contacts	Maximum load = 30 W
Parameter settings	See “Setting the parameters”
Measurement accuracy current (I) and time (t) with 50 Hz	5% (7.5% for RI curve)
Auxiliary power supply (A1/A2)	115/230 VAC (50/60 Hz)
Auxiliary power supply (DB9)	12 – 36 VDC (max. 100 mA)

2.2.1 Available types of circuit breakers

Type	Rated voltage [kV]	Rated current [A]	Rated breaking capacity [kA]
VA-2 12-25/4L	12	400	25
VA-2 12-25/6L	12	630	25
VA-2 12-25/8L	12	800	25
VA-2 12-25/12L	12	1250	25
VA-2 17.5-25/4L	17.5	400	25
VA-2 17.5-25/6L	17.5	630	25
VA-2 17.5-25/8L	17.5	800	25
VA-2 17.5-25/12L	17.5	1250	25
VA-2 24-20/4L	24	400	20
VA-2 24-20/6L	24	630	20
VA-2 24-20/8L	24	800	20
VA-2 24-20/12L	24	1250	20
VA-2RP 12-25/4L	12	400	25
VA-2RP 12-25/6L	12	630	25
VA-2RP 12-25/8L	12	800	25
VA-2RP 17.5-25/4L	17.5	400	25
VA-2RP 17.5-25/6L	17.5	630	25

2.3 Dimensions and weights of the circuit breaker VA-2

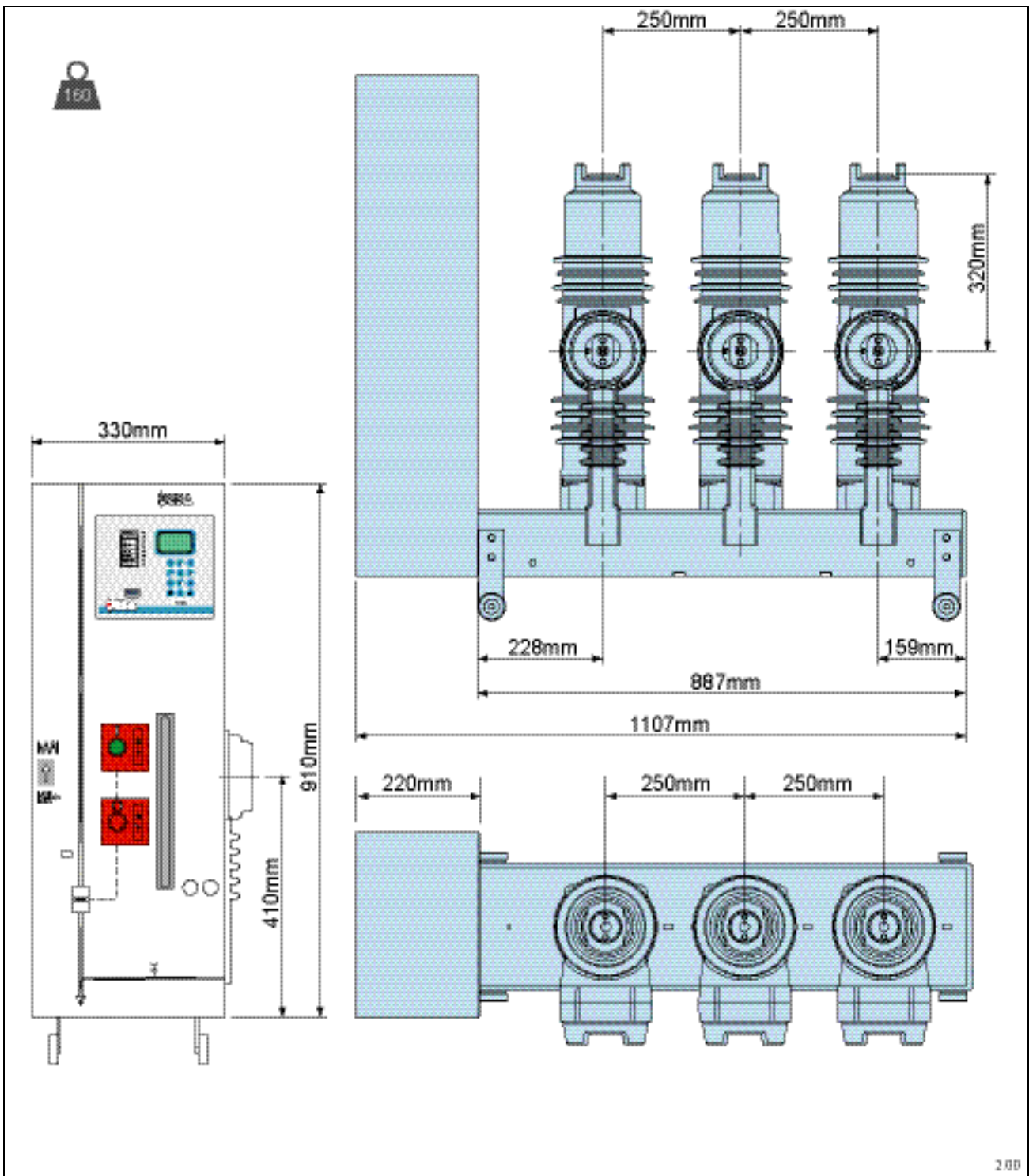

2.4 Dimensions and weight of the digital protection relay RP600

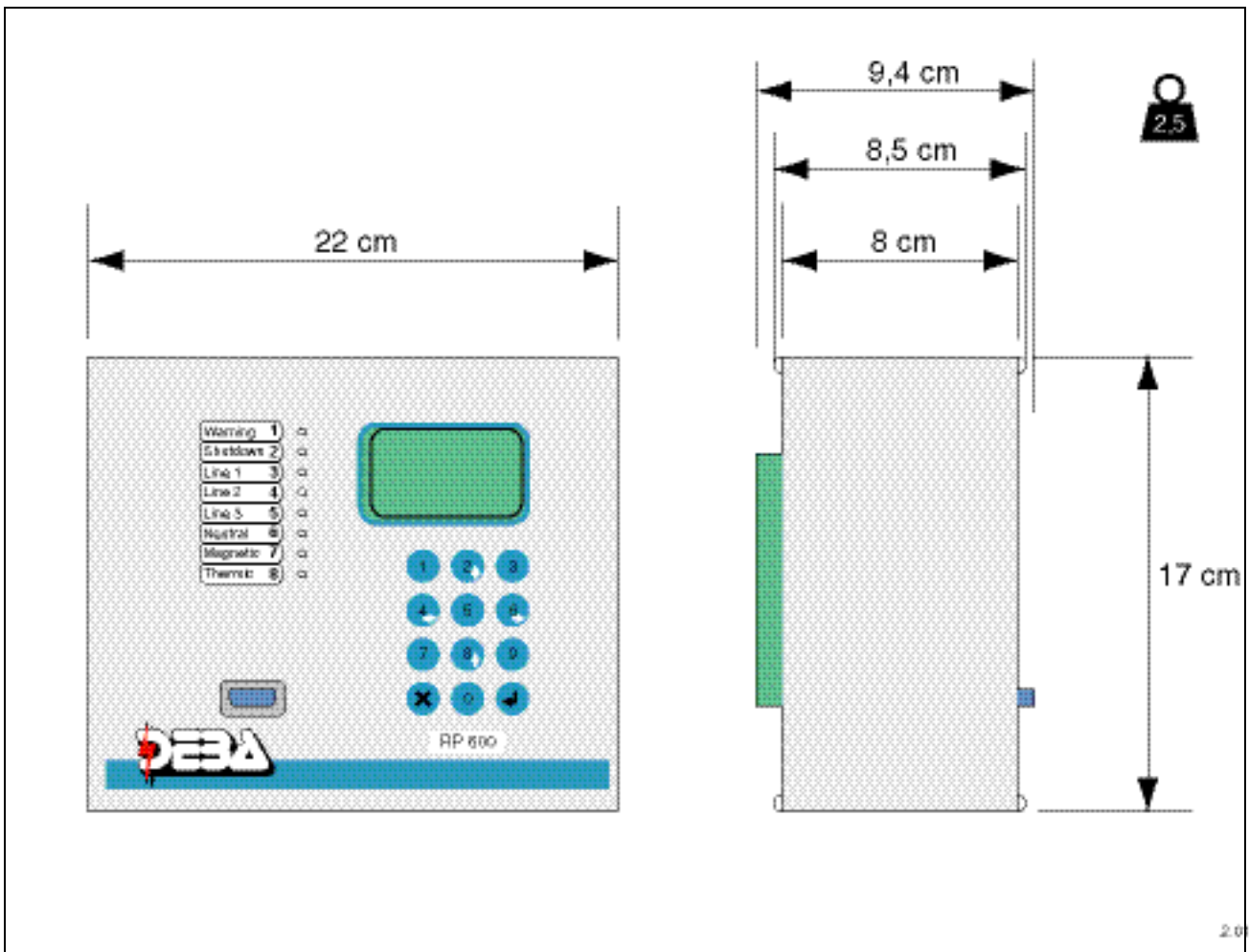

2.5 Available mechanical drive options

Option	Code	VA-2 / VA – 2RP	
		Manual	Electric
1st trip coil for VA-2/VA-2RP		○	●
1 st trip coil for VA-2/VA-2RP 24VDC	VA001392	○	●
1 st trip coil for VA-2/VA-2RP 48VDC	VA001393	○	●
1 st trip coil for VA-2/VA-2RP 60VDC	VA001394	○	●
1 st trip coil for VA-2/VA-2RP 110VAC	VA001395	○	●
1 st trip coil for VA-2/VA-2RP 110VDC	VA001396	○	●
1 st trip coil for VA-2/VA-2RP 220VAC	VA001397	○	●
2 nd trip coil for VA-2/VA-2RP 24VDC	VA001392	○	○
2 nd trip coil for VA-2/VA-2RP 48VDC	VA001393	○	○
2 nd trip coil for VA-2/VA-2RP 60VDC	VA001394	○	○
2 nd trip coil for VA-2/VA-2RP 110VAC	VA001395	○	○
2 nd trip coil for VA-2/VA-2RP 110VDC	VA001396	○	○
2 nd trip coil for VA-2/VA-2RP 220VAC	VA001397	○	○
3 rd trip coil for VA-2/VA-2RP 24VDC	VA001392	○	○
3 rd trip coil for VA-2/VA-2RP 48VDC	VA001393	○	○
3 rd trip coil for VA-2/VA-2RP 60VDC	VA001394	○	○
3 rd trip coil for VA-2/VA-2RP 110VAC	VA001395	○	○
3 rd trip coil for VA-2/VA-2RP 110VDC	VA001396	○	○
3 rd trip coil for VA-2/VA-2RP 220VAC	VA001397	○	○
Delayed undervoltage coil VA-2/VA-2RP		○	○
Direct undervoltage coil VA-2/VA-2RP 24VDC	VA001292	○	○
Direct undervoltage coil VA-2/VA-2RP 48VDC	VA001293	○	○
Direct undervoltage coil VA-2/VA-2RP 60VDC	VA001294	○	○
Direct undervoltage coil VA-2/VA-2RP 110VAC	VA001295	○	○
Direct undervoltage coil VA-2/VA-2RP 110VDC	VA001296	○	○
Direct undervoltage coil VA-2/VA-2RP 220VAC	VA001297	○	○
Delayed undervoltage coil VA-2/VA-2RP 24VDC	VA000292	○	○
Delayed undervoltage coil VA-2/VA-2RP 48VDC	VA000293	○	○
Delayed undervoltage coil VA-2/VA-2RP 60VDC	VA000294	○	○
Delayed undervoltage coil VA-2/VA-2RP 110VAC	VA000295	○	○
Delayed undervoltage coil VA-2/VA-2RP 110VDC	VA000296	○	○
Delayed undervoltage coil VA-2/VA-2RP 220VAC	VA000297	○	○
Closing coil VA-2/VA-2RP		○	●
Closing coil VA-2 / VA-2RP 24 VDC	VA000392	○	○
Closing coil VA-2 / VA-2RP 48 VDC	VA000393	○	○
Closing coil VA-2 / VA-2RP 60 VDC	VA000394	○	○
Closing coil VA-2 / VA-2RP 110 VAC	VA000395	○	○
Closing coil VA-2 / VA-2RP 110 VDC	VA000396	○	○
Closing coil VA-2 / VA-2RP 220 VAC	VA000397	○	○

Option	Code	VA-2 / VA – 2RP	
		Manual	Electric
Closing coil VA-2/VA-2RP		<input type="radio"/>	<input checked="" type="radio"/>
Motor equipment VA-2/VA-2RP 24VDC	VA000013	<input type="radio"/>	<input type="radio"/>
Motor equipment VA-2/VA-2RP 48VDC	VA000014	<input type="radio"/>	<input type="radio"/>
Motor equipment VA-2/VA-2RP 60VDC	VA000012	<input type="radio"/>	<input type="radio"/>
Motor equipment VA-2/VA-2RP 110VAC	VA000015	<input type="radio"/>	<input type="radio"/>
Motor equipment VA-2/VA-2RP 110VDC	VA000011	<input type="radio"/>	<input type="radio"/>
Motor equipment VA-2/VA-2RP 220VAC	VA000010	<input type="radio"/>	<input type="radio"/>
Auxiliary contact VA-2/VA-2RP		<input type="radio"/>	<input type="radio"/>
Limit switch of the motor VA-2/VA-2RP	VA252020	<input type="radio"/>	<input type="radio"/>
Auxiliary contact 1NO/1NC tensioned spring VA-2/VA-2RP	VA000056	<input type="radio"/>	<input type="radio"/>
Auxiliary contact 2NO/2NC tensioned spring VA-2/VA-2RP	VA000057	<input type="radio"/>	<input type="radio"/>
Auxiliary contact 3NO/3NC tensioned spring VA-2/VA-2RP	VA000058	<input type="radio"/>	<input type="radio"/>
Auxiliary contact 1NO/1NC on VA-2/VA-2RP	VA000041	<input type="radio"/>	<input type="radio"/>
Auxiliary contact 2NO/2NC on VA-2/VA-2RP	VA000042	<input type="radio"/>	<input type="radio"/>
Auxiliary contact 3NO/3NC on VA-2/VA-2RP	VA000043	<input type="radio"/>	<input type="radio"/>
Auxiliary contact 4NO/4NC on VA-2/VA-2RP	VA000044	<input type="radio"/>	<input type="radio"/>
Auxiliary contact 5NO/5NC on VA-2/VA-2RP	VA000045	<input type="radio"/>	<input type="radio"/>
Auxiliary contact 6NO/6NC on VA-2/VA-2RP	VA000046	<input type="radio"/>	<input type="radio"/>
Auxiliary contact 7NO/7NC on VA-2/VA-2RP	VA000047	<input type="radio"/>	<input type="radio"/>
Auxiliary contact 8NO/8NC on VA-2/VA-2RP	VA000048	<input type="radio"/>	<input type="radio"/>
Auxiliary contact 9NO/9NC on VA-2/VA-2RP	VA000049	<input type="radio"/>	<input type="radio"/>
Auxiliary contact 10NO/10NC on VA-2/VA-2RP	VA000050	<input type="radio"/>	<input type="radio"/>
Other options VA-2/VA-2RP		<input type="radio"/>	<input type="radio"/>
Lock open circuit breaker VA-2 / VA-2RP with Ronis lock	DF000067	<input type="radio"/>	<input type="radio"/>
Locking device on the switching-on button	DF000068	<input type="radio"/>	<input type="radio"/>
Operation counter on VA-2/VA-2RP	VA514519	<input checked="" type="radio"/>	<input checked="" type="radio"/>
●	Available by default		
○	Available as option		

3 TRANSPORT AND STORAGE

3.1 Safety regulations – transport



These instructions are to be observed during transport of the circuit breaker. The locally applicable safety regulations and guidelines should also be complied with.

- See also: " General safety regulations and instructions ".
- Before transporting the circuit breaker:
 - Ensure proper securing of the circuit breaker on the truck, forklift truck or hand trolley.
 - Check that all components are properly fixed.
- Do not tilt the circuit breaker, but always transport it in upright position.
- Do not place any other objects or tools on top or loosely close to the circuit breakers to be transported.



Protect the circuit breaker against water and other liquids.



Circuit breakers that have fallen over during transport or that have been seriously damaged otherwise, must always be sent back for inspection to Mevoco n.v. before commissioning the circuit breaker(s).



On the back side of the packaging a 'ShockWatch' has been attached. If the colour of this has changed, the circuit breaker should always be sent back for inspection to Mevoco n.v.



3.2 Safety regulations – storage

- Also see “General safety regulations and instructions”.
- Respect the surrounding conditions. See "Surrounding conditions".
- Never stack circuit breakers on top of each other.
- Keep the circuit breaker(s) in a dry, dust-free area.

4 INSTALLATION

The installation applies when a circuit breaker is ordered separately, and as a result, not available in the cubicle.

4.1 Safety regulations – installation

4.1.1 General

- Also see “General safety regulations and instructions”.
- Never leave tools or fastening material in or on top of the circuit breaker.
- Install the circuit breaker only in areas that fully comply with the following recommendations (according to IEC 60694).

4.1.2 Recommendations - installation area

The recommendations concerning the installation area are divided into recommendations concerning:

- the floor surface
- the surrounding conditions
- the ventilation
- the free height of the installation area

4.1.2.1 Floor surface

The surface on which the circuit breaker (indirect) is to be installed, must be sufficiently strong and completely level. The maximum permissible difference in level is **2 mm/m**.

4.1.2.2 Environment conditions

The circuit breaker has been designed for **indoor installation** under the following conditions:

description	value
Ambient temperature	min. -15 °C - max. +45 °C
Relative air humidity	min. 10% - max. 70% (without formation of condensation)
Installation altitude	max. 1.000 m above sea level

In practice this means one has to:

- Avoid installation in dusty areas.
- Avoid installation in areas with high relative air humidity.
- Avoid installation in areas subject to lightning strikes.
- Avoid installation in surroundings where the circuit breaker can come into contact with aggressive gases or fluids.



Contact Mevoco n.v. if the circuit breaker is to be installed in areas where the aforementioned environment conditions cannot be guaranteed.

4.1.2.3 Ventilation

- Ensure good ventilation of the installation area.
- Protect the ventilation openings so that small animals or vermin do not have access to the installation area.

4.2 Unpacking

The circuit breaker is packed default in protective foil and mounted on an euro pallet. The most suitable place for unpacking the circuit breaker is of course the final installation area.

- Check the ShockWatch.
- Clip or cut the straps securing the circuit breaker to the pallet.
- Carefully remove the protection foil.
- Check the circuit breaker for any (transport) damage.



If parts are missing or damaged, contact the transporter or Mevoco n.v. Seriously damaged circuit breakers must always be returned to Mevoco n.v.

- Carefully lift the circuit breaker off the pallet.



Remove, if applicable, the upper bolt that attaches the four wheels to the frame. Place the four crane hooks (1) and secure these using the bolt. Tighten the bolt well. Attach a hoisting cable (2) crosswise to the crane hooks. Lift the circuit breaker at the crossing point of the hoisting cables. If you apply this possibility, use suitable hoisting and lifting machinery that are in a perfect condition and have sufficient hoisting capacity only. Use hoisting cables covered with nylon to avoid damage to the VA-2.

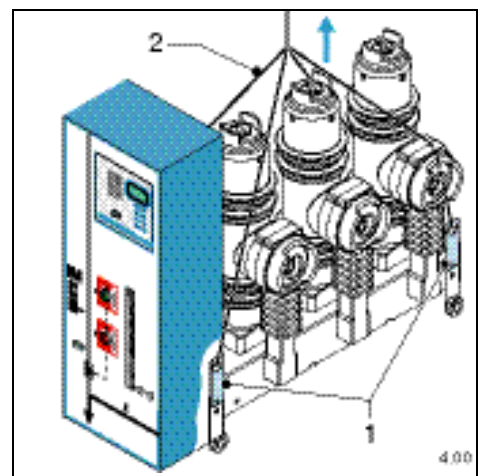

Make sure while hoisting the switch that all safety regulations for hoisting are complied with and that the hoisting is done by qualified personnel.

- Remove the pallet.



After the packaging material used has been removed in accordance with prevailing legislation, the mounting of the circuit breaker can be started.

4.3 Mounting

The circuit breaker is delivered completely assembled and is ready for mounting..



For detailed (dis)mounting instructions for the used VA-2 in DF-2 cubicles, see “DF-2, Medium Voltage Switchgear, The Modular Concept”.

Observe the points below before mounting the circuit breaker:



Check that no loose objects (screws, packaging, tools and the like) are left on the circuit breaker or in the cubicle. Remove all foreign objects.



Make sure that the circuit breaker and the three poles in particular are dust-free and free from metal particles. Therefore clean the circuit breaker, if necessary, with a non-fluffy cloth and a non-corrosive cleaning agent.



Make sure that all electrical voltages applied are in accordance with the specified values.



Make sure that the contact surfaces of the lower and upper connections are clean. Therefore brush the contact surfaces with a suitable brush and then apply a thin layer of Vaseline. Evenly spread the Vaseline.

4.3.1 Earthing of the circuit breaker

The earthing connection of the circuit breaker is located on the rear side of the chassis. Use M12 bolts for mounting the earthing.

5 USE

5.1 Safety regulations – use

See also: “General safety regulations and instructions”.

Use of the circuit breaker is restricted to qualified and trained operators, while observing the locally applicable safety regulations and guidelines.

5.2 Operation of the circuit breaker VA-2

The circuit breaker is operated by the local operating panel on the front side of the circuit breaker. The following controls and indicators can be distinguished:

- A Switching-on button
- B Switching-off button
- C Switch position indicator
- D Spring position indicator
- E Operation counter
- F Handle
- G Cover
- H Cover fastening screws
- I Digital protection relay (optional)
- J Ronis lock(s)

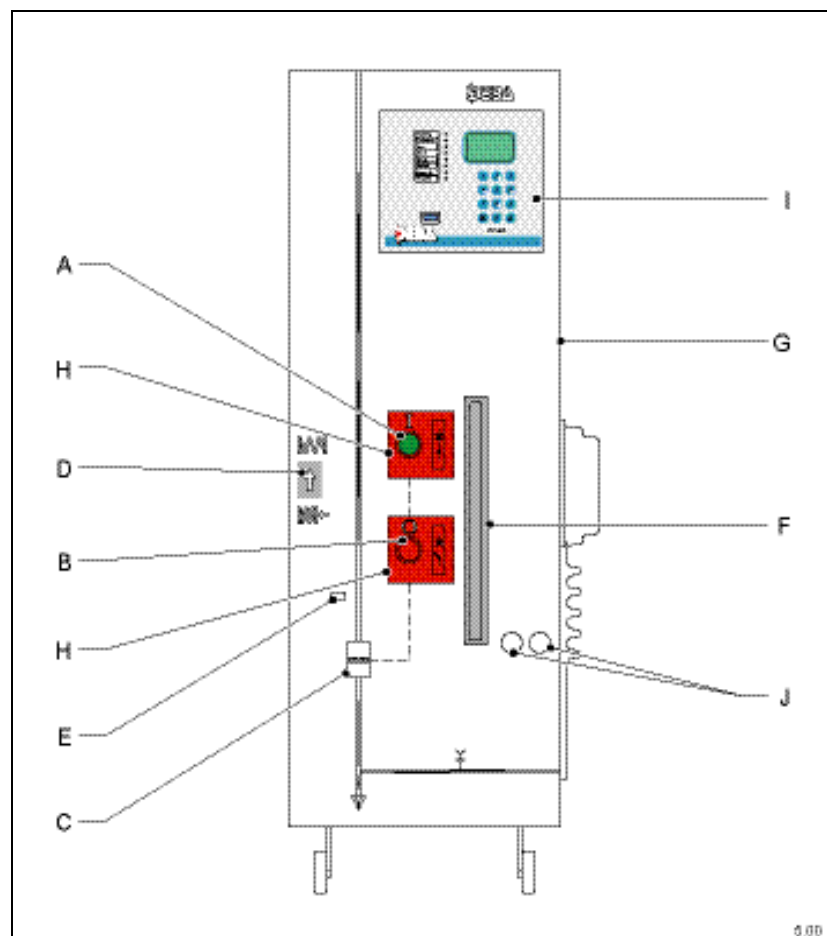

5.2.1 Switching on the circuit breaker

Before the circuit breaker can be switched on, the following minimum conditions should be met:

- The circuit breaker must be open (i.e. the contacts opened).
- The compression spring must be tensioned (see "Tensioning the compression spring").

When these conditions are met, the circuit breaker can be switched on in two different ways (fig. 5.0):

- Manually by pressing the switching-on button (A).
- Electrically by operating the shunt-closing coil (optional).



Avoid damaging the mechanical drive when the cover (G) has been removed. Never change the position of the circuit breaker when the cover (G) has been removed. For safety reasons it is strictly forbidden to switch while the cover has been removed.

5.2.2 Switching off the circuit breaker

Before the circuit breaker can be switched off, the following minimum condition should be met:

- The circuit breaker must be closed (i.e. the contacts closed).

If this condition is met, the circuit breaker can be switched off in a number of different ways (dependent on the options used) (fig. 5.0):

- Manually by pressing the switching-off button (B).
- Automatically by sending an electric impulse to the first or second shunt-trip coil.
- Automatically by zero voltage with the undervoltage trip coil (optional) or the time-delayed undervoltage trip coil (optional).
- Automatically when there is a fault current (current that occurs at a fault, thermal overload or short circuit) when the digital protection relay RP600 is used.



Avoid damaging the mechanical drive when the cover (G) has been removed. Never operate the position of the circuit breaker when the cover (G) has been removed.

5.2.3 Compressing the spring

The compression spring can be tensioned if one of the following conditions is met:

- The circuit breaker is open (i.e. the contacts opened) and the spring is relaxed.
- The circuit breaker is closed (i.e. the contacts closed).

If these conditions are met, the compression spring can be tensioned in two different ways (fig. 5.0)

- Manually by tensioning the spring using the handle (F) until the spring position indicator (D) is pointing down.
- Automatically by using an electric motor (optional). If one of the above-mentioned conditions is met, the electric motor will automatically tension the compression spring in less than 15 seconds, making it ready for the next closing and opening cycle.

5.3 Operation of the digital protection relay RP600

The RP600 is operated with the local operating panel on the front side of the RP600. The following controls, function keys and indicators can be distinguished:

- A LCD display
- B Numeric function keys 0 - 9
- C Escape key
- D Enter key ↵
- E Arrow keys ←, ↑, →, ↓
- F LED indicators
- G PC interface

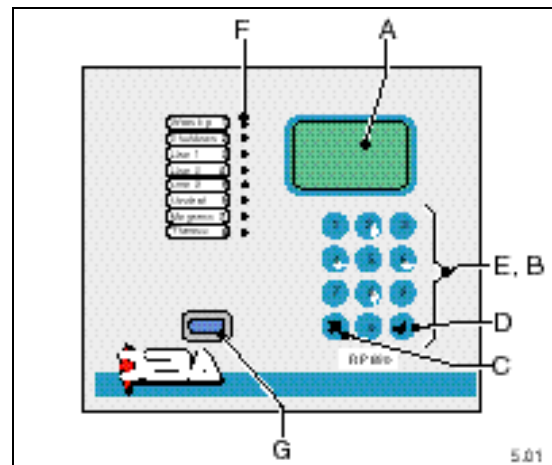

The menu-mechanical driven operation of the RP600 is easy and is performed step by step:

1. Use the arrow keys to scroll through all menus. A menu can be scrolled through with arrow keys ↑ and ↓. With arrow keys ← and → you can switch between menus.
2. Use the arrow keys to select the desired menu item.
3. Press the Enter key ↵ to be able to change the value of the selected menu item.
4. Press the numeric keys 0 – 9 or the arrow keys ←, ↑, →, ↓ to enter the desired value.
5. Press the Enter key ↵ to save the value.



As long as the value has not been saved, the action can be cancelled by pressing the Escape key ×.



Menus marked by “ $\Delta\nabla$ ” cannot be scrolled through without using an auxiliary power supply. Menus marked by “ \blacktriangledown ” can be scrolled through without using an auxiliary power supply.



In order to actually change and save a value, this must first be enabled. Select 'Program' in the 'Options' menu and change the value to 'enabled'. As a result, the RP600 will be disabled and the 'warning' LED will light up.



By pressing the Escape key × you can switch from any menu to a menu at a higher level.



If the operating panel is not used for 20 seconds, the program automatically returns to the main screen, displaying the size of the four currents (L1, L2, L3 and N), see “Reading current values”.



For some menu items the Enter key ↵ must be pressed twice to save the change. This concerns the following menu items: 'Delete faults' and 'Default values'. By pressing the Escape key × the action can be cancelled.



When the RP600 leaves the factory, all parameters are set to default values. These default values can always be reset. Select 'Default values' in the 'Options' menu and change the value to 'set'.

5.3.1 Menu Structure

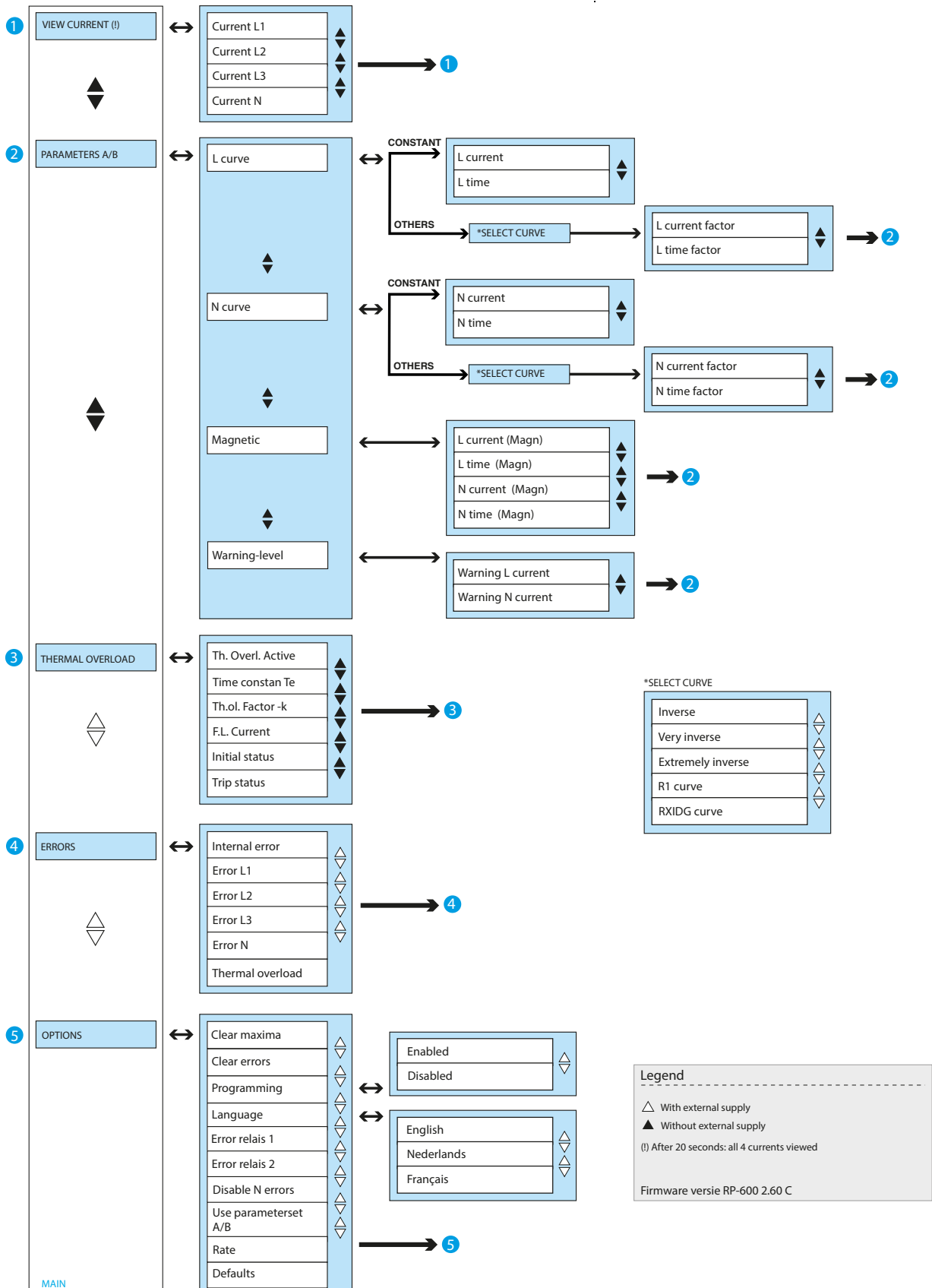

5.3.2 Programming the RP600

5.3.2.1 Programming via the local operating panel



When leaving the factory, all parameters of the RP600 have been set to default values. These default values can always be reset. Select 'Default values' in the 'Options' menu and change the value to 'set'.

The menu-mechanical driven operation makes the RP600 easy to program, see “Menu structure”. When programming, follow the recommended sequence given below:

1. Connect an external auxiliary power supply to be able to program the RP600 fully, see “Connecting an auxiliary power supply”.
2. Prepare the RP600 so that it can be programmed. Select 'Program' in the 'Options' menu. Press the Enter key ↵ to change the value into 'enabled'.



A parameter can be changed if the text 'Ep' (Edit parameter) is shown at the bottom left in the display. At the same time the parameter value will flash. Change the value using the numeric function keys and/or the arrow keys. Press the Enter key ↵ to save the parameter value or press the Escape key × to cancel the action, see “Operating the local operating panel”.



As long as 'Program' has the value 'disabled', no value changes will be accepted.



When the programming function is enabled, the protection function and the measurement functions of the RP600 are disabled. As an indication, the LED 'WARNING' will light up and the output contact (WARN) will be enabled.

3. Select the desired language. Select 'Language' in the 'Options' menu. Go to the desired language ('English', 'Nederlands', 'Français') and press the Enter key ↵, see also “Selecting the language”.
4. Set the current ratio of the current transformers used. Select 'Ratio' in the 'Options' menu. Press the Enter key ↵ to change the value. Enter the correct value ('1:50', '1:150', '1:200', '1:400', '1:600'). Press the Enter key ↵ again to save the value, see also “Setting the current ratio”.
5. Set the desired parameters for the L Curve, N Curve and Magnetic. Select the desired characteristic ('constant', 'inverse', 'very inverse', 'extremely inverse', 'RI curve', 'RXIDG curve') for the L and N Curves. Then set the graph. Four variables ('Current (Th)', 'Time (Th)', 'Current Factor', 'Time Factor') must be set for each graph. Set the correct value for each variable, see also “Setting the parameters”.
6. Exit the programming. Select 'Program' in the 'Options' menu. Press the Enter key ↵ to change the value into 'disabled'. The protection function and the measurement

functions of the RP600 are re-enabled. As an indication, the LED 'WARNING' will go out.

5.3.2.1.1 Configuring fault relays R1 and R2

Configure the functions of fault relays R1 and R2 as follows:

Select 'Fault relay 1' or 'Fault relay 2' in the 'Options' menu and select the desired value. Press the Enter key ↵ to be able to change the value and press the Enter key ↵ again to save the configuration.

Parameter to be set	Content of LCD display	Possible values	Default value
Fault relays 1 and 2	Fault relays 1 / 2 value	Not used Every fault Overcurrent Short circuit current Fault on L Overcurrent on L Short circuit on L Fault on N Overcurrent on N Short circuit on N Warning Warning L Warning N	Not used

5.3.2.1.2 Configuring input IN1

Configure the function of digital input IN1 as follows:

Select 'Ignore N faults' or 'Parameter set A/B' in the 'Options' menu and select the desired value. Press the Enter key ↵ to be able to change the value and press the Enter key ↵ again to save the configuration.

Parameter to be set	Content of LCD display	Possible values	Default value
Ignore N faults	Ignore N faults value	Do not ignore	Do not ignore
		If IN1 is on	
		If IN1 is off	
Parameter set A/B	Parameter set A/B value	Always ignore	Only set A
		Only set A	
		Only set B	
		B if IN1 is on*	
		B if IN1 is off*	

(*) If IN1 is active, parameter set B is selected, otherwise parameter set A.

(**) If IN1 is inactive, parameter set B is selected, otherwise parameter set A.

5.3.2.1.3 Selecting the language of the operating panel

Select the language of the operating panel as follows:

Select 'Language' in the 'Options' menu and select the desired value. Press the Enter key ↵ to change the value.

Parameter to be set	Content of LCD display	Possible values	Default value
Language	Language value	English	English
		Nederlands	
		Français	

5.3.2.1.4 Setting the current ratio

Set the current ratio to suit the current transformers used. Select 'Ratio' in the 'Options' menu. Press the Enter key ↵ to change the value. Enter the correct value. Press the Enter key ↵ again to save the value.

Parameter to be set	Content of LCD display	Possible values	Default value
Current ratio	Ratio value	1 : 50	1 : 50
		1 : 150	
		1 : 200	
		1 : 400	
		1 : 600	

5.3.2.1.5 Setting the parameters

The parameters of the RP600 with regard to the L curve, N curve and magnetic can be set as follows. Set parameters of L curve:

Select 'L curve', 'N curve' or 'Magnetic' in the 'Parameters' menu. Select the relevant parameter the value of which must be set. Press the Enter key ↵ to be able to change the value and press the Enter key ↵ again to save the changed value. Do this for all parameters that need setting.



When leaving the factory, all parameters of the RP600 have been set to default values. It is always possible to return to these default values. Select 'Default values' in the 'Options' menu and change the value to 'set'.

Parameter to be set	Content of LCD display	Minimum value	Maximum value	Default value
L Curve	L Curve value	see "Menu structure"	see "Menu structure"	Constant
L Thermal Current	L Current (Th) value	0.40 In	2.50 In	1.00 In
L Thermal Time	L Time (Th) value	0.00 s	99.98 s / ∞	1.00 s
L Factor	L Current Factor value	0.40 In	2.50 In	1.00 In
L-K Factor	L Time Factor value	0.05	1.00	1.00
N Curve	N Curve value	see "Menu structure"	see "Menu structure"	Constant
N Thermal Current	N Current (Th) value	0.20 In	2.50 In	0.80 In
N Thermal Time	N Time (Th) value	0.00 s	99.98 s / ∞	1.00 s
L warning	Critical current L value	0.20 In	2.50 In	0.80 In

Parameter to be set	Content of LCD display	Minimum value	Maximum value	Default value
N warning	Critical current N value	0.10 In	2.50 In	0.60 In
N Factor	N Current Factor value	0.02 A	0.80 A	0.02 A
N-K Factor	N Time Factor value	0.05	1.00	1.00
L Current Magnetic	L Current (Magn) value	0.40 In	12.00 In	4.00 In
L Time Magnetic	L Time (Magn) value	0.00 s	99.98 s / ∞	0.50 s
N Current Magnetic	N Current (Magn) value	0.40 In	7.50 In / ∞	∞ In
N Time Magnetic	N Current (Magn) value	0.00 s	99.98 s / ∞	0.50 s

5.3.2.2 Programming using RP600 software

The RP600 can also be programmed using the RP600 software supplied. The RP600 software must be installed on a PC/laptop and communicates with the RP600 via a serial PC interface, see “Communication via PC interface”. The following settings can be made:

- Language
- Current ratio
- Functions of fault relays R1 and R2
- L curve parameters for set A (and possibly for set B)
- N curve parameters for set A (and possibly for set B)

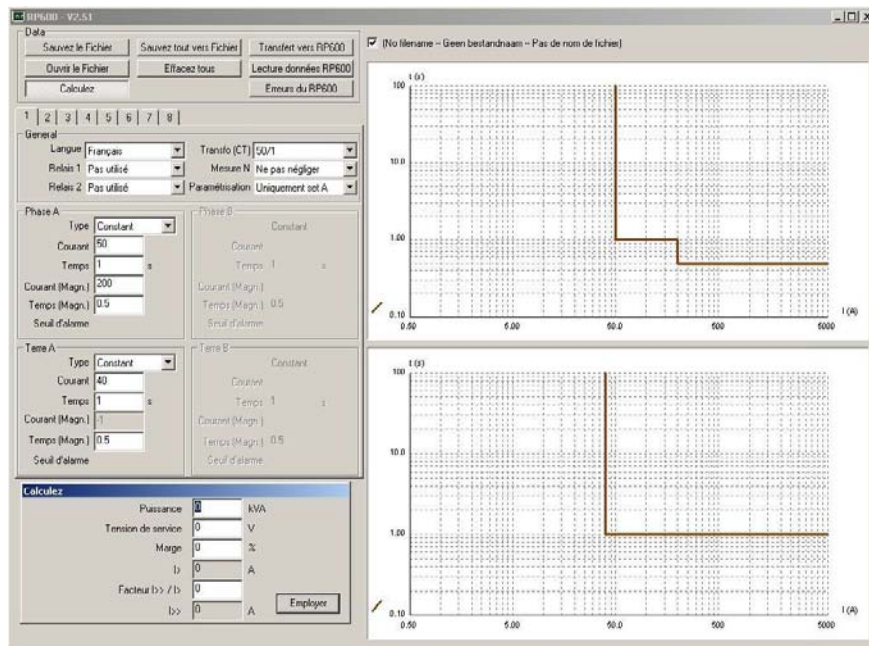

The screen has been divided into five sections:

- Data
- General
- Line
- Ground
- Breaking characteristics

With the aid of the eight available parameter sets (tab sheets), just as many different RP600 configurations can be set and compared with each other.

5.3.2.2.1 Data

Button	Function
Save file	Saves the selected parameter set in a file.
Read file	Loads the data from a file. If this file contains one parameter set, this data is included in the selected parameter set. If this file contains several parameter sets, all existing parameter sets are overwritten.
Save all data	Saves all eight parameter sets in a file.
Delete all data	Deletes the data of all eight parameter sets.
Write to RP600	Opens the COM port and writes the data from the selected parameter set to the RP600.
Read the RP600	Opens the COM port, reads the data of the RP600 and overwrites the selected parameter set.
RP600 Faults	Opens the COM port and reads the last fault values. Faults can also be deleted.

5.3.2.2.2 General

Button	Function
Language	Setting the desired language.
Transfo	Setting the current ratio.
Relay 1	Setting the function of fault relay 1.
Relay 2	Setting the function of fault relay 2.
Measure N	When the checking of earth fault is active (instead of IN1).
Param-set	Determines which parameter set is active (A or B).

5.3.2.2.3 Line

Button	Function
Type	Setting the type of breaking characteristics for L phase currents.
Current	Setting the thermal current for the L phase currents.
Time	Setting the breaking time for the L phase currents.
Current (Magn)	Setting the current for the L phase currents (magnetic).
Time (Magn)	Setting the breaking time for the L phase currents (magnetic).
Warning	Level at which a warning fault can be given on R1 or R2.

5.3.2.2.4 Ground

Button	Function
Type	Setting the type of breaking characteristics for N residual current.
Current	Setting the thermal current for the N residual current.
Time	Setting the breaking time for the N residual current.
Current (Magn)	Setting the current for the N residual current (magnetic).
Time (Magn)	Setting the breaking time for the N residual current (magnetic).
Warning	Level at which a warning fault can be given on R1 or R2.

5.3.2.2.5 Breaking characteristics

The top characteristic graphically shows all settings for the L phase currents. The bottom characteristic graphically shows all settings for the N residual current. Each parameter set is identified by means of a unique colour:

Parameter set	Colour	Parameter set	Colour
1	Brown	5	Green
2	Red	6	Blue
3	Orange	7	Purple
4	Yellow	8	Grey

The different parameter sets can be compared with each other on the basis of the different colours. Each line is a combination of the thermal and the magnetic settings.

5.3.3 Reading current values

The size of the current values of the three phase currents of L1, L2 and L3 and the residual current of N can be read from the display. Select 'Look at currents' in the main menu. Select the desired current and press the Enter key ↵ to look at the current value. The display could look as follows for the respective currents (the maximum measured current value is given between brackets):

Current of L1 125 A (160 A)
Current of L2 130 A (158 A)
Current of L3 128 A (155 A)
Current of N 1 A (3 A)



The maximum measured current value that is given between brackets can be reset to zero at all times. Select 'Delete maxima' in the 'Options' menu. Press the Enter key ↵ to reset all maximum measured current values to zero.

If the operating panel is not used for 20 seconds, the program automatically returns to the main screen, displaying the size of the four currents (L1, L2, L3 and N) in amps. The display could look as follows:

1= 125	2= 130
3= 128	N= 1

5.3.4 Reading fault information

Information about the status of the RP600 can be read in two ways:

- From the LED indicators, see “Fault information from the LED indicators”
- From the display, see “Fault information from the display”
- Fault information from the LED indicators is combined with supplementary information that is shown on the display.

5.3.4.1 Fault information from the LED indicators

The function of all LED indicators is fixed. If the assigned function of a certain LED indicator is enabled because a fault occurs in the field, the corresponding indicator will light red continuously, under the condition that an auxiliary power supply is used, see "Connecting an auxiliary power supply". Supplementary information about the size of the fault current can be read on the display.

LED indicator	Meaning
WARNING	Warning. The RP600 is not operational, because the programming function is active or because there is an internal fault. The corresponding output contact (WARN) is closed, see "Detecting internal faults".
ERROR	The RP600 has detected a fault current. More information can be read on the remaining LED indicators. The corresponding output contact (ERR) was short circuit, see "Detecting external faults".
L1	Fault on L1
L2	Fault on L2
L3	Fault on L3
N	Fault on N
MAGNETIC	Short circuit current
THERMIC	Overcurrent



Each new external fault will re-initialise the fault information of the LED indicators.

5.3.4.2 Fault information from the display

Information about the fault can be read on the display. There can be an external or an internal fault. Information about the faults is saved in:

- The external fault memory, see "Reading the external fault memory"
- The internal fault memory, see "Reading the internal fault memory"

Besides information about faults, information is also saved on incidents that have occurred. Incidents can also be read on the display, see "Reading registered incidents".

5.3.4.2.1 Reading the fault memory

When an external fault occurs, the LED indicators will display the nature of the external fault. The latest (most recent) external fault is saved in the 'external fault memory'. Specific information about the external fault (size and duration of the fault current) can be read on the LCD display. Examples of possible reports that can occur with the various external faults are:

External fault	Content of LCD display
Internal fault	Internal fault (*)
Overcurrent/short circuit L1	Fault current of L1 150 A (99.99 s)
Overcurrent/short circuit L2	Fault current of L2 0 A (0.00 s)
Overcurrent/short circuit L3	Fault current of L3 0 A (0.00 s)
Overcurrent/short circuit N	Fault current of N 0 A (0.00 s)



The 'external fault memory' can be reset as follows. Select 'Delete faults' in the 'Options' menu and press the Enter key ↵ twice.



Information about the fault currents is deleted from the external fault memory if there is no external auxiliary power supply present or if it is interrupted.

(*) With an internal fault, the following reports are possible:

- “No fault”, the RP600 is OK.
- “Memory fault”, the memory of the RP600 has become corrupted. Return the RP600 to Mevoco n.v. for reprogrammin.
- “Parameters invalid”, one or more parameters are invalid. Check all parameters and restore invalid parameters. Use the operating panel or the PC (with RP600 software) for this. You can also use the option menu to return to the default values. If the fault persists, return the RP600 to Mevoco n.v. for reprogramming..

6 MAINTENANCE

6.1 Safety regulations - maintenance

- Also see “General safety regulations and instructions”.
- The maintenance activities described are restricted to qualified and trained operators only while observing the locally applicable safety regulations and guidelines.
- All other maintenance activities not described are restricted to trained and authorised service personnel.
- Ensure that the circuit breaker is voltage free before carrying out the maintenance activities described.
- Only put the circuit breaker back into operation after any removed front panels and doors of the DF-2 cubicle(s) have been refitted and the work carried out has been carefully checked.
- Never leave tools or attachment material in or on top of the circuit breaker or the DF-2 cubicle(s).

6.2 Maintenance - general

The circuit breaker has been designed to operate problem free with a minimum of maintenance. To guarantee this a few simple maintenance and cleaning activities are required. If you exercise the necessary care and carefully carry out the activities described, any problems will usually be discovered and corrected before they lead to a standstill.

Technical maintenance of the circuit breaker must be carried out after 10,000 switching cycles. For this read the actual number of switches from the operation counter (A). This involves the adjustment of the compression and the stroke length of the contacts. For this purpose, contact Mevoco n.v. or request help from trained and authorised service personnel.

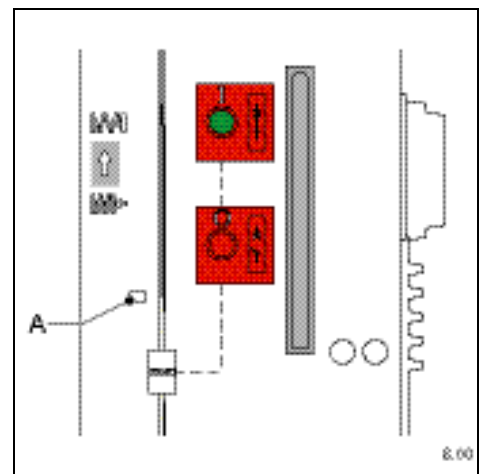

When one or more vacuum interrupters have switched higher kA(s) values than specified (see Technical specifications), then these vacuum interrupter(s) should be replaced. For this purpose, contact Mevoco N.V.

6.2.1 General checking activities

- Regularly carry out a thorough, general visual inspection.
- Make sure that the circuit breaker is dust-free. Particularly check the poles and the insulating parts for accumulation of dust particles.

In order to be able to check and clean the circuit breaker, the circuit breaker must be removed from the DF-2 cubicle. For detailed (dis)mounting instructions for the used VA-2 in DF-2 cubicle(s), see “DF-2, Medium Voltage Switchgear, The Modular Concept”.

6.2.2 Cleaning the circuit breaker



Contamination of the circuit breaker can initially be limited by following the recommendations on the installation area. See “Recommendations - installation area”.

Adhere to the following steps when cleaning the circuit breaker:

- Read the safety regulations first. See “Safety regulations – maintenance”
- Clean the outside with a non-fluffy cloth and a non-corrosive cleaning agent.
- Thoroughly rub the cleaned surfaces dry.

7 CONNECTING DIAGRAMS

7.1 Numbering of terminals

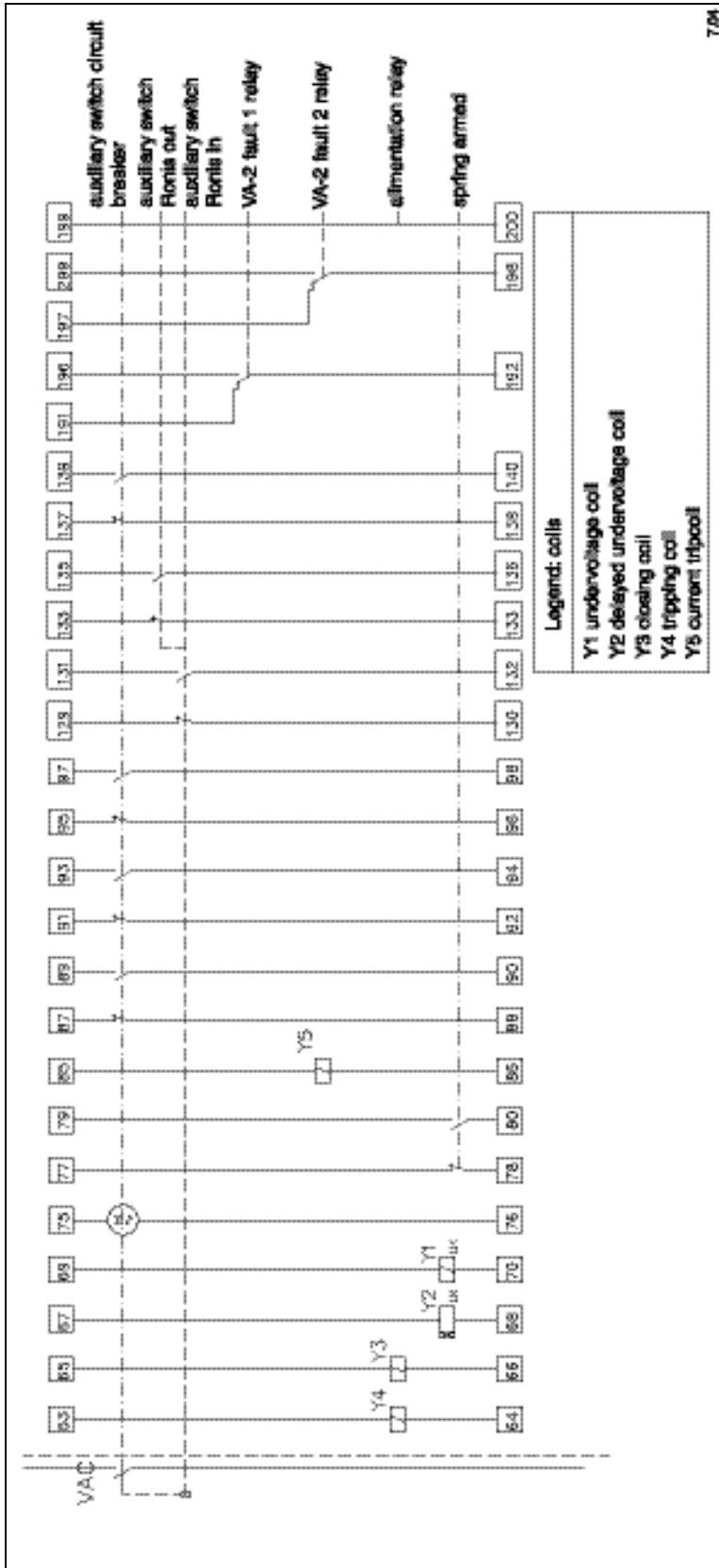

pos. number	description	pos. number	description
63_64	TRIP COIL DF-P / VA-2	95_96	AUXILIARY CONTACT NC ON VA-2
65_66	CLOSING COIL DF-PVA-2	97_98	AUXILIARY CONTACT NC ON VA-2
67_68	UNDER VOLTAGE COIL TIME DELAYED ON DF-PVA-2	129_130	NG ON RONIS VA-2 IN
69_70	UNDERVOLTAGE COIL ON DF-PVA-2	131_132	NO ON RONIS VA-2 IN
75_76	MOTOR VA-2	133_134	NG ON RONIS VA-2 OUT
77_78	NG SPRING REINFORCED DF-PVA-2	135_136	NO ON RONIS VA-2 OUT
79_80	NO SPRING REINFORCED DF-PVA-2	137_138	AUXILIARY CONTACT NC ON VA-2
85_86	AMPERE-METRICAL COIL VA-2	139_140	AUXILIARY CONTACT NC ON VA-2
87_88	AUXILIARY CONTACT NC ON VA-2	191_192_196	MAKE-AND-BREAK CONTACT VA-2 RELAY FAULT1 NO/NC
89_90	AUXILIARY CONTACT NC ON VA-2	197_198_299	MAKE-AND-BREAK CONTACT VA-2 RELAY FAULT2 NO/NC
91_92	AUXILIARY CONTACT NC ON VA-2	199_200	POWER SUPPLY RELAY VA-2 (RP600-PS421-VIP)

7.2 Connecting diagram of the digital protection relay RP600

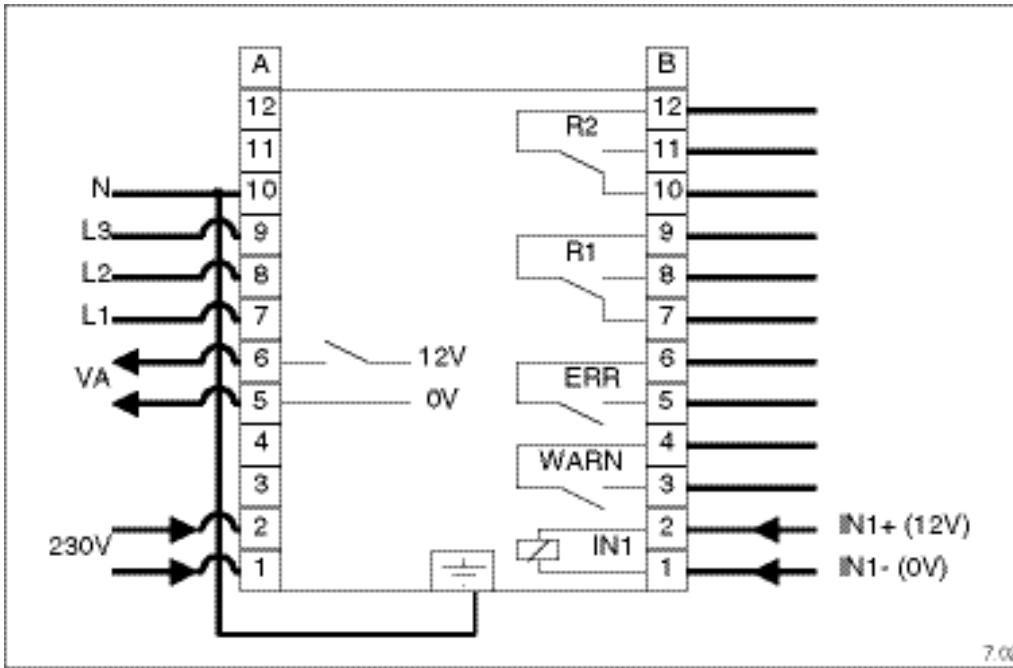

7.3 Selecting current the value current transformers (VA-2RP)

A VA-2RP always consists of a circuit breaker VA-2, a relay RP600 and three standard current transformers, hereafter referred to as 'CT's'.

The different rated current values of the 'CT's' are 50 A, 150 A, 200 A, 400 A and 600A. The rated currents have been determined in relation to the relay, that is to say $(1 \times I_n)$ relay. For example, in the range $I_n = 150 \text{ A}$ a current of 300A will on the primary side of the transformers be measured as $(2 \times I_n)$ by the relay.

The RP600 is as a default set to $I_n = 50\text{A}$ in the factory. Afterwards setting a different current value is done as follows:

- Dismount the protection cover (fig. 7.03C) from the VA-2RP.
 - Unscrew the 2 (fig. 7.03A) screws(A).
 - Remove the two screws(A) with their PVC rings(B) (fig. 7.03B).
 - Remove the sheet-metal shield.
- Dismount the relay RP600, making the connection terminals visible. This step can be skipped after some experience has been gained.

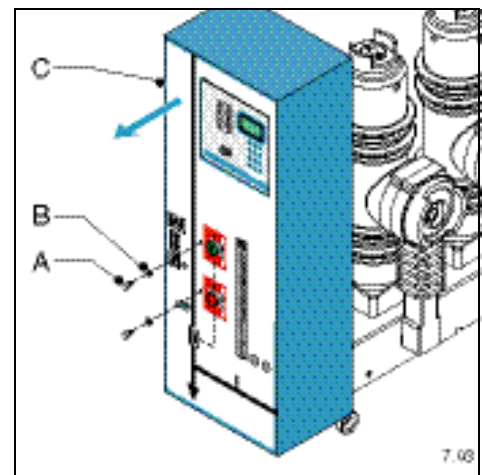

- Behind the RP600 the following figure (sticker) appears.

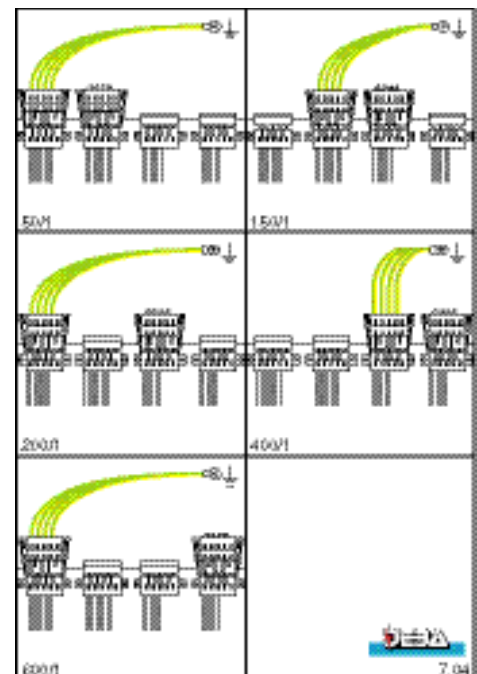

- The connection terminals mounted on the rail are the outputs of the CT's, from left to right S1, S2, S3 and S4 (fig. 7.05A/B/C/D).
- The connectors (fig. 7.05E/F) are used for setting the desired current value.
 - The default setting is $I_n = 50$ A: the connector of the earthing (fig. 7.05E) has been connected with the terminal S1 (fig. 7.05A), the connector of the RP600 (fig. 7.05F) has been connected with terminal S2 (fig. 7.05B).

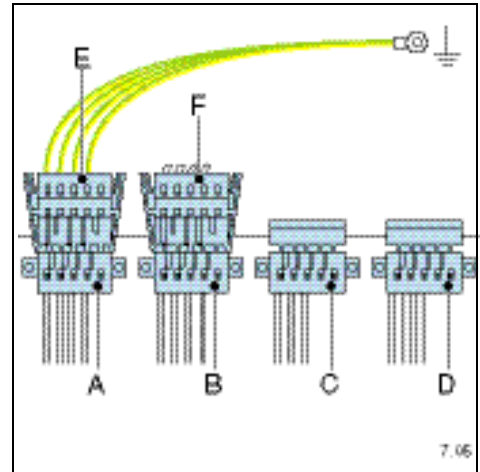

- As an example the current value is set to 150 A. Loosen both connectors (fig. 7.06E/F). Connect the earthing connector (fig. 7.06E) with terminal S2 (fig. 7.06B) and the connector of the RP600 (fig. 7.06F) with terminal S3 (fig. 7.06C).

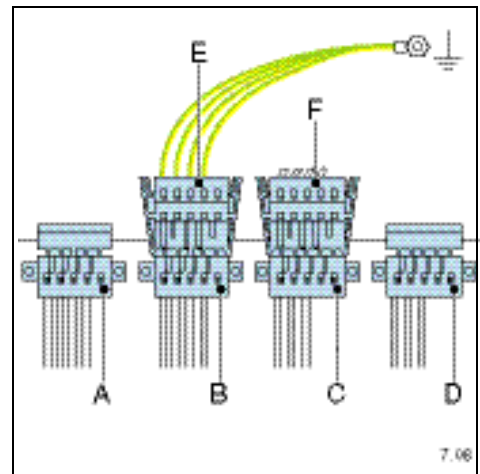

- Set the other current values in the same way. On the inside of the circuit breaker it has been indicated how the connectors are to be placed for which current value, also see fig. 7.04.
- Make sure that the connectors are always thoroughly locked.
- Reposition the RP600 and the protection cover in the reverse order of the dismantling operations.

8 CIRCUIT BREAKERS AND THE ENVIRONMENT

8.1 Packing material



The packing material mainly consists of:

- (untreated) wood
- plastic straps
- plastic film

- Contact the local public sanitation department for the details of recycling or an environment-friendly way of processing the packing materials.
- Offer the packing material as instructed (separated).



For Belgium: Euro pallets must be returned to Mevoco n.v. after installation of the circuit breaker.

8.2 Disposal of the circuit breaker

For reuse of electrical components, the circuit breaker can be returned to Mevoco n.v. at the end of its lifetime (or earlier in case of damage).

On consultation, the entire circuit breaker can be returned as well. If this is not possible, the circuit breaker must be processed in an environment-friendly way.



- Contact the local public sanitation department and offer the material in the prescribed manner (separated).

9 MOUNTING OPTIONS

One or more of the options given below can be mounted on the VA-2 (possibly combined):

- closing coil(s)
- trip coil(s)
- tensioning motor
- undervoltage coil(s)
- key lock(s)
- auxiliary contact(s)
- operation counter

9.1 Closing coil

A closing coil can be mounted on the mechanical drive mechanism of the VA-2 (RP), whether or not self-driven. With the help of this closing coil the circuit breaker can be closed automatically after having been manually or automatically reinforced.

9.1.1 Preparation for mounting

The following preparations must always be made **before** starting to mount the closing coil(s):

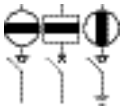

- Make the entire medium voltage switchgear and the circuit breaker voltage free.
 - On the concerned cubicle, open both the load-break switch and the circuit breakers.
 - The HV cable connection side must also be voltage free.
 - Close the earthing switch of the medium voltage switchgear.
-
- Remove the door of the cubicle.
 - Dismount the cover from the VA-2 (RP).
 - Unscrew the 2 (fig. 9.01A) screws.
 - Remove the two screws with their PVC rings (fig. 9.01B).
 - Remove the cover.

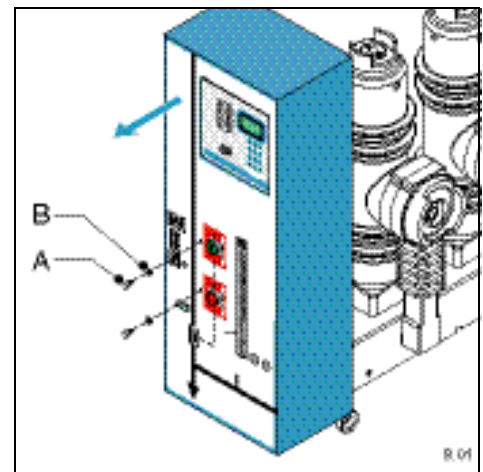

9.1.2 Mounting the closing coil - general

Special mounting kits are available for mounting the closing coil. The composition of these mounting kits depends on the type of closing coil.

Available mounting kits dependent on coil type:

order number	description
VA000392	Closing coil VA-2 / VA-2RP 24 VDC
VA000393	Closing coil VA-2 / VA-2RP 48 VDC
VA000394	Closing coil VA-2 / VA-2RP 60 VDC
VA000395	Closing coil VA-2 / VA-2RP 110 VAC
VA000396	Closing coil VA-2 / VA-2RP 110 VDC
VA000397	Closing coil VA-2 / VA-2RP 220 VAC

Order number mounting kit VA00039x consists of:

order number	description	number	pos. no.
Dependent on the chosen coil:			
OP20xxxx	Coil depending on the voltage	1	fig. 9.02 A
Mounting material:			
GR040909	Cyl. screw DIN 912 M4x6 full thread	2	fig. 9.02 B
GR041604	Lock washer DIN 6798A Ø M4	2	fig. 9.02 C
VA407270	Shaft closing coil mech. VA-2 G.V.	1	fig. 9.02 D
GR043130	Split pin DIN 94 Ø 3.2 x 20	1	fig. 9.02 E

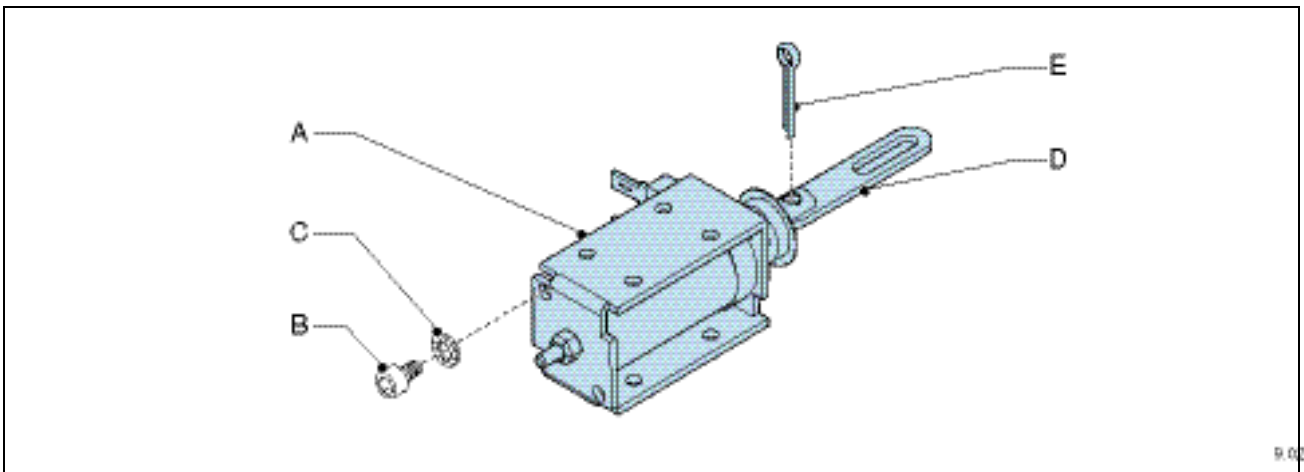

9.1.2.1 Mounting instructions

- Slide the shaft (D) of the closing coil (A) over the premounted bolt on the white disc.
- Mount the closing coil from the top side of the support using the screws (B) and the lock washers (C).



The bolts anchoring the coil are mounted diagonally, as indicated on the drawing.



Between the bolt and the beginning of the slot in the shaft (D) there must be two millimetres play. There must be two millimetres play between the end of the threaded shaft and the lock nut.



Check the operation of the closing coil by pressing it - with the circuit breaker still opened and not reinforced - by hand. The shaft must be free and be able to move smoothly.

- Electrically connect the coil according to the connection diagram delivered.

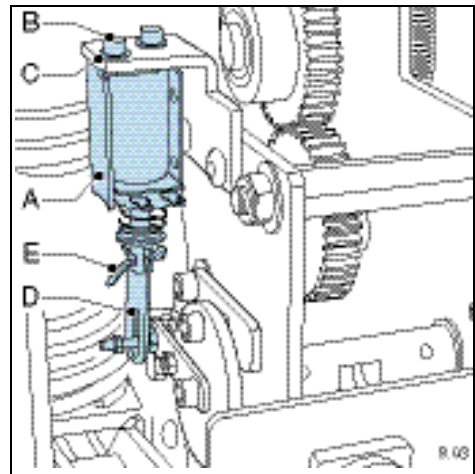

9.1.2.1.1 Electrical monitoring with external power source.



Prevent burning out of the coil. the voltage to the coil if the load-break switch is opened.

Place an auxiliary contact if supply comes from an external power source (battery).

9.1.3 Final checking and commissioning

The following actions must always be carried out after mounting the closing coil(s).

- Check that the fitting materials are properly attached.
- Test the closing coil circuit using a multimeter. If the closing coil is supplied by an external power source, an auxiliary contact must always be placed.
- Mount the sheet metal shield of the VA-2 (RP).
- Put the entire medium voltage switchgear and the circuit breaker into operation.

9.2 Triping coil(s)

One or more triping coils can be mounted on the mechanical drive of the VA-2(RP). With the help of these triping coil(s) the compression spring that is to provide the energy for the opening cycle of the VA-2 can be automatically relaxed. After the VA-2(RP) has been closed, the circuit breaker can be opened with the help of the trip coil.

The compression spring that is to provide the energy for the opening cycle of the VA-2(RP) is activated by the triping coil that puts a trip mechanism into operation.

9.2.1 Preparation for mounting

The following preparations must always be taken **before** you start mounting the trip coil(s):

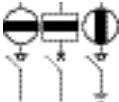
- 
- Make the entire medium voltage switchgear and the circuit breaker voltage free.
 - Open on the particular cubicle both the load-break switch and the circuit breakers.
 - The HV cable connection side must also be voltage free.
 - Close the earthing switch of the medium voltage switchgear.
- Remove the door of the medium voltage switchgear.
 - Dismount the sheet cover from the VA-2 (RP).
 - Unscrew the 2 (fig. 9.01A) screws.
 - Remove the two screws with their PVC rings (fig. 9.01B).
 - Remove the cover.

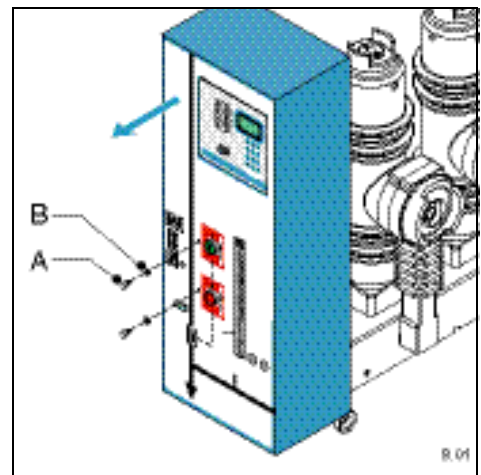

9.2.2 Mounting the triping coil(s) - general

Special mounting kits are available for mounting the trip coil(s). The composition of these mounting kits depends on the type of trip coil.

Available mounting kits dependent on coil type

order number	description
VA001392	Tripping coil VA-2 / VA-2RP 24 VDC
VA001393	Tripping coil VA-2 / VA-2RP 48 VDC
VA001394	Tripping coil VA-2 / VA-2RP 60 VDC
VA001395	Tripping coil VA-2 / VA-2RP 110 VAC
VA001396	Tripping coil VA-2 / VA-2RP 110 VDC
VA001397	Tripping coil VA-2 / VA-2RP 220 VAC

Order number mounting kit: VA00139x consists of:

order number	description	number	pos. no.
Dependent on the chosen coil:			
OP20xxxx	Coil depending on the voltage	1	fig. 9.02 A
Mounting material:			
GR040909	Cyl. screw DIN 912 M4x6 full thread	2	fig. 9.02 B
GR041604	Lock washer DIN 6798A Ø M4	2	fig. 9.02 C
VA407296	Shaft shunt-trip coil mech. VA-2 G.V.	1	fig. 9.02 D
GR043130	Split pin DIN 94 Ø 3.2 x 20	1	fig. 9.02 E

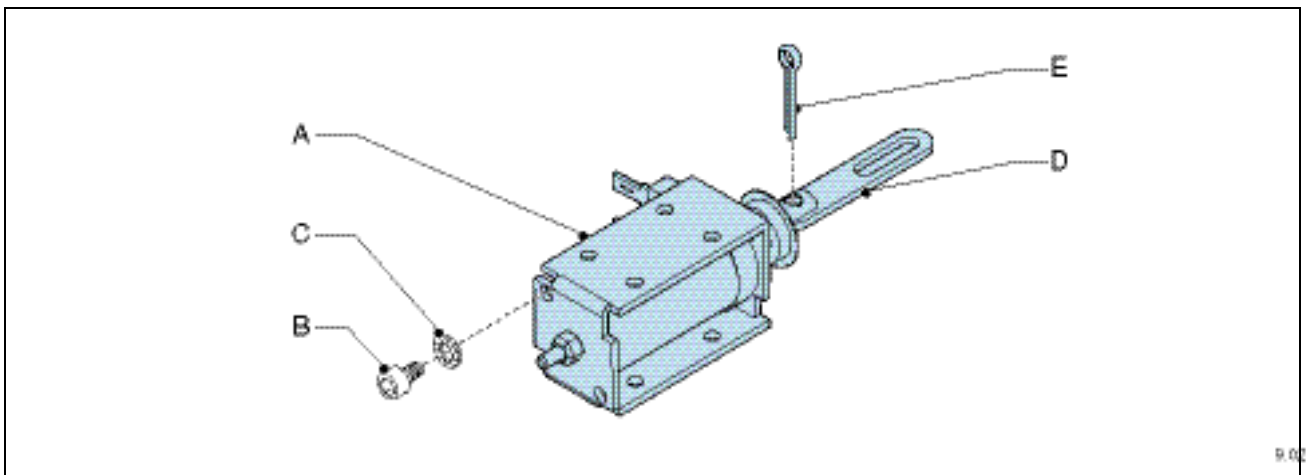

9.2.2.1 Mounting instructions

- Slide the shaft (D) of the trip coil (A) over the premounted bolt on the white disc.
- Mount from the top side of the sheet metal support the tripping coil using the screws (B) and the lock washers (C).

i The bolts anchoring the coil are mounted diagonally, as indicated in the drawing.

i Check the operation of the tripping coil by pressing it - with the circuit breaker still opened and not closed - by hand. The shaft must be free and be able to move smoothly.

- Electrically connect the coil according to the electrical diagram delivered.

i The connection cards of the coil(s) point at the tensioning handle of the VA-2 (RP). Places for two tripping coils have been provided. They are placed along both sides of the shaft that rests on the white disc.

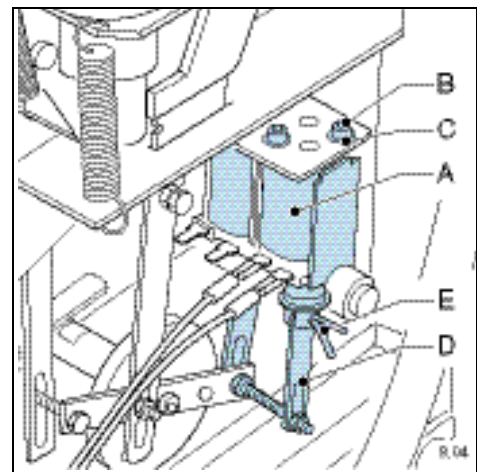

9.2.2.1.1 Electrical monitoring with external power source



Prevent burning out of the coil. Interrupt the voltage to the coil if the load break switch is open.

Place an auxiliary contact if supply comes from an external power source (battery).

9.2.3 Final check and commissioning

The following activities must always be carried out after mounting the tripping coil.

- Check that the fitting materials are properly attached.
- Test the circuit using a multimeter. If the tripping coil is supplied by an external power source, an auxiliary contact must always be installed.
- Mount the sheet-metal shield of the VA-2 (RP).
- Put the entire medium voltage switchgear and the circuit breaker into operation.

9.3 Positioning a motor

A motor can be mounted on the mechanical drive of the VA-2(RP). With the help of this motor the compression spring that is to provide the energy for the closing and opening cycles can be automatically tensioned. In almost all cases a VA-2(RP) with motor can also be equipped with a closing and tripping coil.

9.3.1 Preparation for mounting

The following preparations must always be made **before** starting to mount the motor:

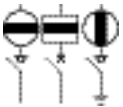

- Make the entire medium voltage switchgear and the circuit breaker voltage free.
- On the concerned cubicle, open both the load-break switch and the circuit breakers.
- The HV cable connection side must also be voltage free.
- Close the earthing switch of the medium voltage switchgear.

- Remove the door of the medium voltage switchgear.
- Dismount the cover from the VA-2 (RP).
 - Unscrew the two (fig. 9.01A) screws.
 - Remove the two screws with their PVC rings (fig. 9.01B).
 - Remove the cover.

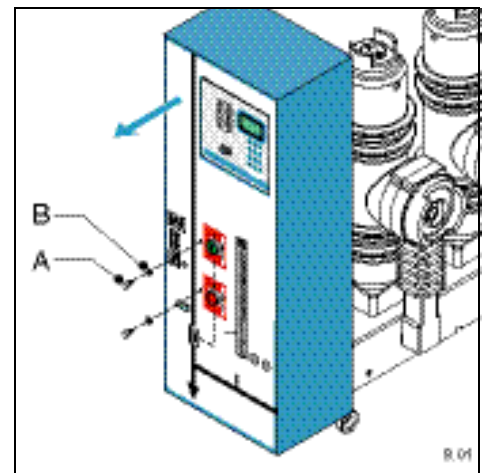

9.3.2 Mounting the motor - general

Special mounting kits are available for mounting the motor. The composition of these mounting kits depends on the type of motor.

Available mounting kits dependent on motor type:

order number	description
VA000013	Motor equipment VA-2/VA-2RP 24 VDC
VA000014	Motor equipment VA-2/VA-2RP 48 VDC
VA000012	Motor equipment VA-2/VA-2RP 60 VDC
VA000011	Motor equipment VA-2/VA-2RP 110 VDC
VA000015	Motor equipment VA-2/VA-2RP 110 VAC
VA000010	Motor equipment VA-2/VA-2RP 220 VAC
VA000009	Replacement motor VA-2/VA-2RP 220 VAC for serial number 34252
VA000008	Replacement motor VA-2/VA-2RP 110 VAC for serial number 34252
VA000007	Replacement motor VA-2/VA-2RP 110 VDC for serial number 34252
VA000006	Replacement motor VA-2/VA-2RP 48 VDC for serial number 34252
VA000005	Replacement motor VA-2/VA-2RP 24 VDC for serial number 34252

Order number mounting kit: VA00001x consists of:

order number	description	number	pos. no.
Depending on the selected voltage			
OP11xxxx	Motor, gear wheel (possibly a rectifier) depending on voltage	1	fig. 9.05 A
Mounting material:			
GR040645	Hexagonal threaded pin DIN 933 M6x45	1	fig. 9.05 B
GR071956	Schnorr locking cup spring Ø M6	3	fig. 9.05 C
GR040650	Hexagonal threaded pin DIN 933 M6x50	2	fig. 9.05 D
GR041306	Nut with collar RIPP CL10 M6	3	fig. 9.05 E

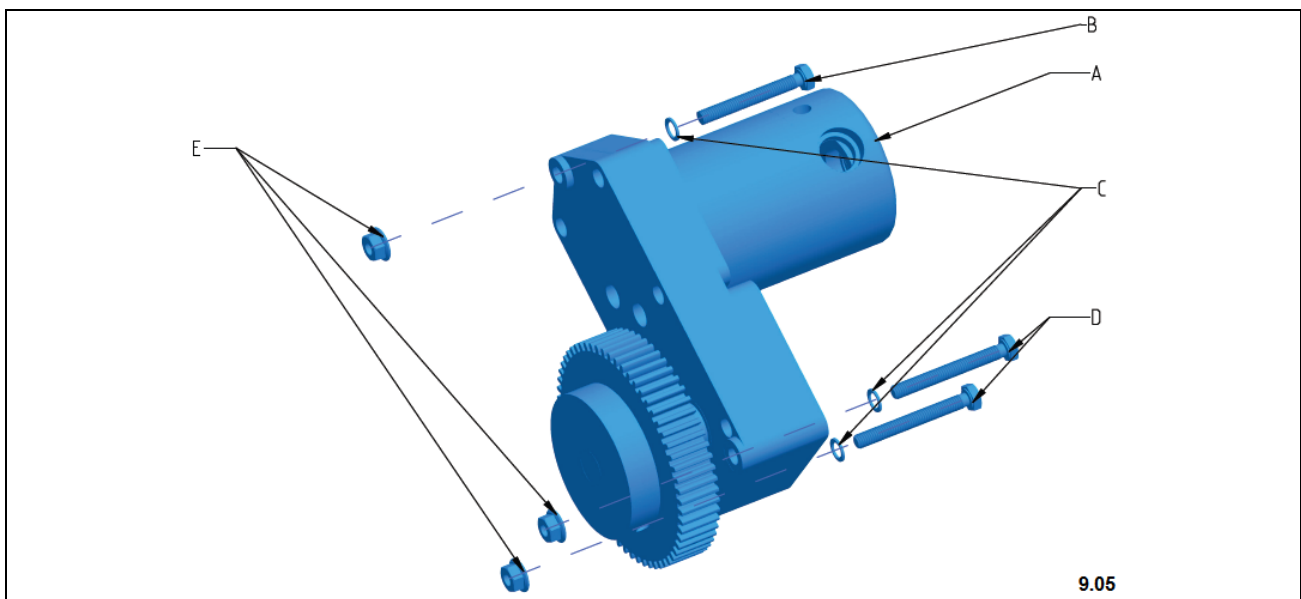

9.3.3 Mounting instructions

- Position the motor with the small gear wheel through the hole provided for this and fasten the motor using the two hexagonal screws (B & D), the locking rings (C) and the nuts (D).



The intermediate gear wheel may not be stuck after mounting the motor. There must be some manually felt play. In this way the teeth of the gear wheels just interlock.

- Depending on the voltage, a rectifier may or may not be supplied. Electrically connect the motor according to the electrical diagram delivered. The motor should also run via contacts to limit the starting and ending rotation positions.

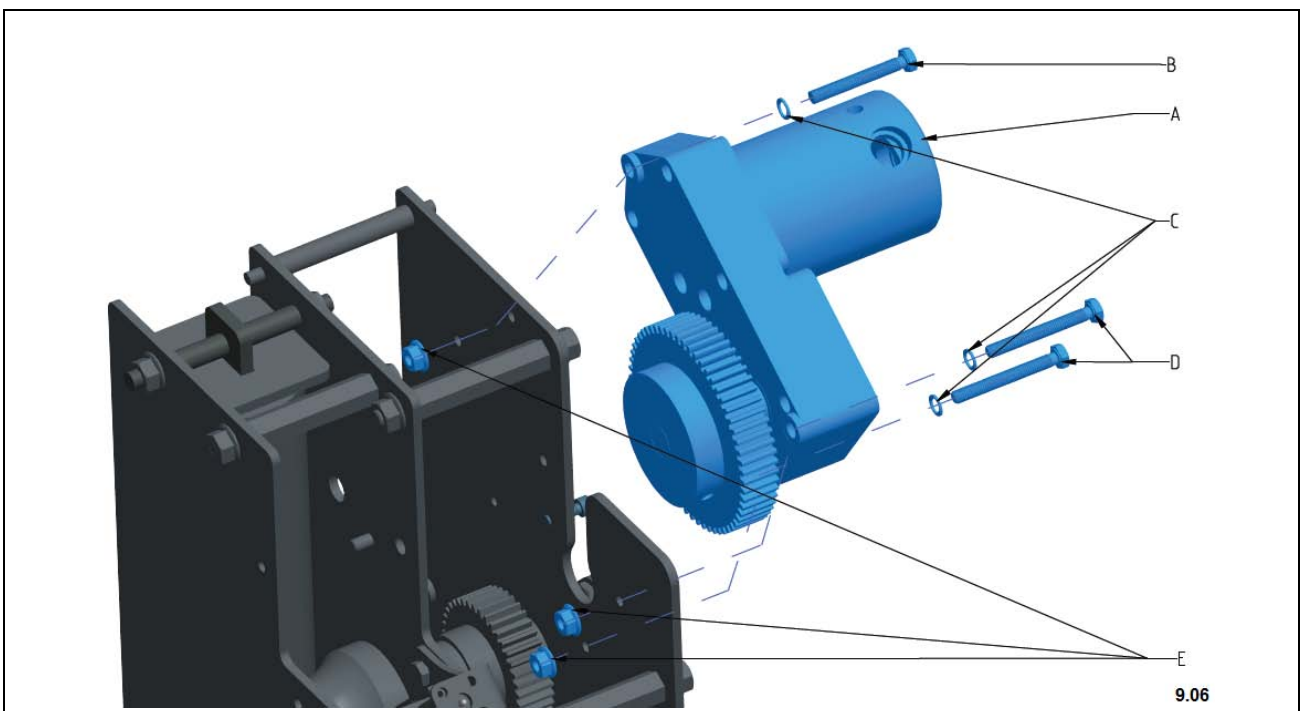

9.3.4 Final check and commissioning

The following activities must always be carried out after mounting the motor.

- Check that the fitting materials are properly attached.
- Check that the intermediate gear wheel is running freely with a little play.
- Mount the sheet-metal shield of the VA-2 (RP).
- Put the entire medium voltage switchgear and the circuit breaker into operation.

9.4 Undervoltage coil

An undervoltage coil can be mounted on the mechanical drive of the VA-2 (RP), motorised, or not. By means of this undervoltage coil the circuit breaker can be opened automatically and from a distance. The undervoltage coil can be time delayed (adjustable) It is possible to provide a VA-2(RP) with an undervoltage coil without delay (direct undervoltage).

9.4.1 Preparation for mounting

The following preparations must always be made **before** starting to mount the undervoltage coil:

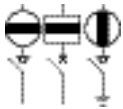

- Make the entire medium voltage switchgear and the circuit breaker voltage free.
- On the concerned cubicle, open both the load-break switch and the circuit breakers.
- The HV cable connection side must also be voltage free.
- Close the knife of the medium voltage switchgear.

- Remove the door of the medium voltage switchgear.
- Dismount the cover from the VA-2 (RP).
 - Unscrew the two (fig. 9.01A) screws.
 - Remove the two screws with their PVC rings (fig. 9.01B).
 - Remove the cover.

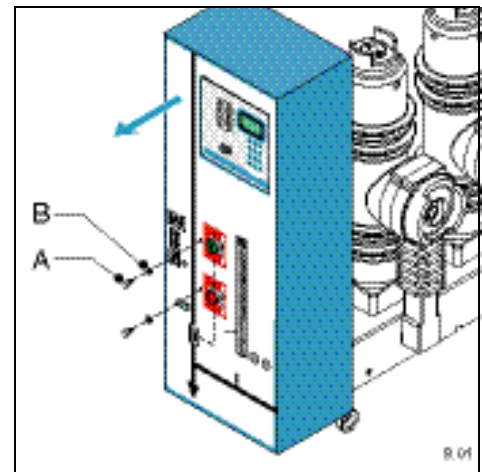

9.4.2 Mounting the undervoltage coil - general

Special mounting kits are available for mounting the undervoltage coil. The composition of these mounting kits depends on the type of undervoltage coil.

Available mounting kits dependent on coil type, with or without time delay:

order number	description
VA001292	Direct undervoltage coil VA-2/VA-2RP 24VDC
VA001293	Direct undervoltage coil VA-2/VA-2RP 48VDC
VA001294	Direct undervoltage coil VA-2/VA-2RP 60VDC
VA001295	Direct undervoltage coil VA-2/VA-2RP 110VAC
VA001296	Direct undervoltage coil VA-2/VA-2RP 110VDC
VA001297	Direct undervoltage coil VA-2/VA-2RP 220VAC
VA000292	Delayed undervoltage coil VA-2/VA-2RP 24VDC
VA000293	Delayed undervoltage coil VA-2/VA-2RP 48VDC
VA000294	Delayed undervoltage coil VA-2/VA-2RP 60VDC
VA000295	Delayed undervoltage coil VA-2/VA-2RP 110VAC
VA000296	Delayed undervoltage coil VA-2/VA-2RP 110VDC
VA000297	Delayed undervoltage coil VA-2/VA-2RP 220VAC



With the VA-2RP the 'undervoltage with accessories' base plate has already been mounted. In this case only the undervoltage support with accessories should be ordered.



With the default model VA-2 without undervoltage coil both the base plate and the undervoltage support with accessories should be ordered.

Order number mounting kit: VA00129x or VA00029x consists of:

order number	description	number	pos. no.
Dependent on the chosen coil:			
OP300024	Undervoltage coil 24 VDC separate	1	fig. 9.07 A
OP300048	Undervoltage coil 48 VDC separate	1	fig. 9.07 A
OP300060	Undervoltage coil 60 VDC separate	1	fig. 9.07 A
OP300110	Undervoltage coil 110 VDC separate	1	fig. 9.07 A
OP301024	Undervoltage coil 24 VAC separate	1	fig. 9.07 A
OP301048	Undervoltage coil 48 VAC separate	1	fig. 9.07 A
OP301060	Undervoltage coil 60 VAC separate	1	fig. 9.07 A
OP301110	Undervoltage coil 110 VAC separate	1	fig. 9.07 A
OP301230	Undervoltage coil 230 VAC separate	1	fig. 9.07 A

order number	description	number	pos. no.
Mounting material:			
OP303000	Timer Isliker (VA00029x series only)	1	fig. 9.07 B
VA407325	Support undervoltage VA-2 G.V.	1	fig. 9.07 C
VA407324	Flange bolt M8x20 RIPP yellow galvanised	1	fig. 9.07 D
VA407323	Support undervoltage VA-2 G.V.	1	fig. 9.07 E
GR040988	Flange bolt M8x20 RIPP yellow galvanised	4	fig. 9.07 F
GR041005	Hexagon nut DIN 934 M5	1	fig. 9.07 G
GR040510	Hexagon tap bolt DIN 933 M5x10	1	fig. 9.07 H
VE036290	Spring undervoltage VA-2	1	fig. 9.07 J
GR040928	Cylindrical screw DIN 912 M6x12	2	fig. 9.07 K
GR071956	Schnorr locking cup spring Ø M6	2	fig. 9.07 L

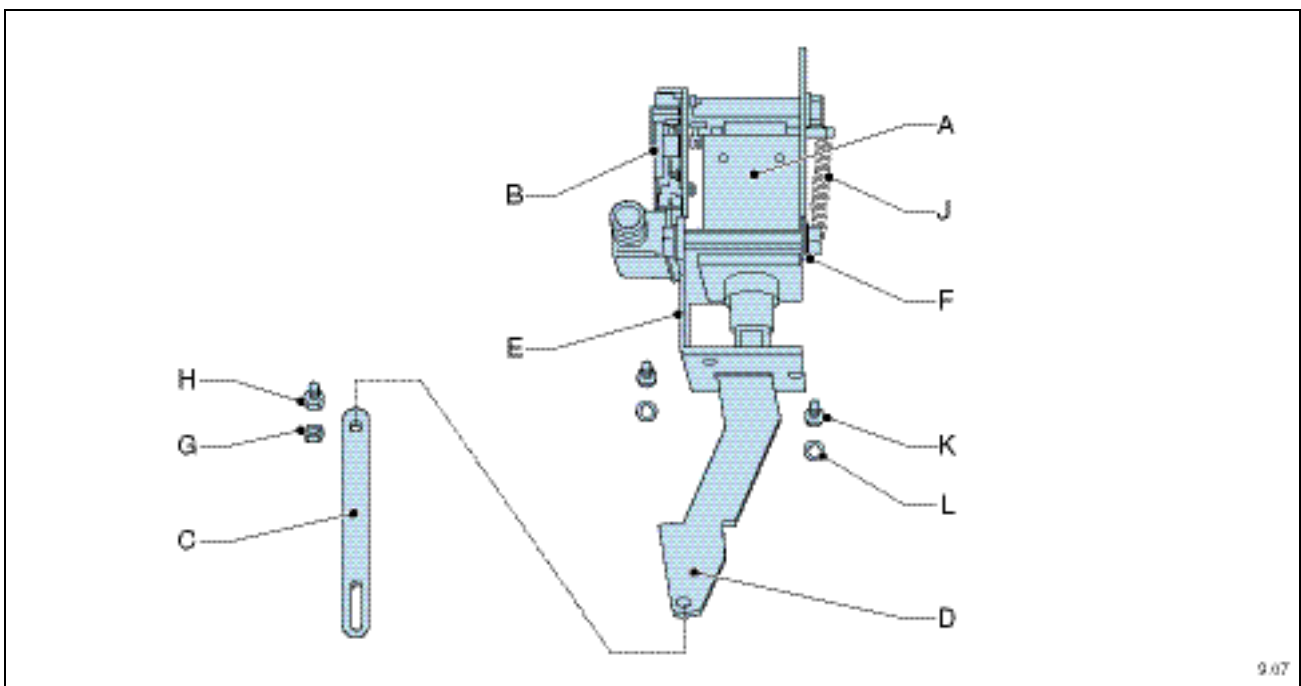

9.07

9.4.3 Mounting procedures

For the VA-2RP or if the base plate for the undervoltage support has already been mounted:

- Check the smooth operation of the undervoltage by manually pressing and releasing.
- Slide the shaft (D) through the slot of the base plate. The minugia is on the left side.
- Mount the two cylindrical screws (K) with Schnorr locking cup spring through the undervoltage support in the base plate (E).
- Dismount the free lock nut on the white disc and slide the shaft (C) over the threaded end that has become free.
- Mount the trip shaft (C) to the tensioning shaft (D) using the hexagon nut (G) and the bolt (H).



The trip shaft (C) must be able to move freely after mounting. Make sure that the end of the bolt is perfectly aligned (zero line) with the shaft (D).

- Remount the lock nut at the original place on the threaded shaft. Turn the lock nut until two millimetres of the threaded shaft are sticking through. This is the proper clearance.

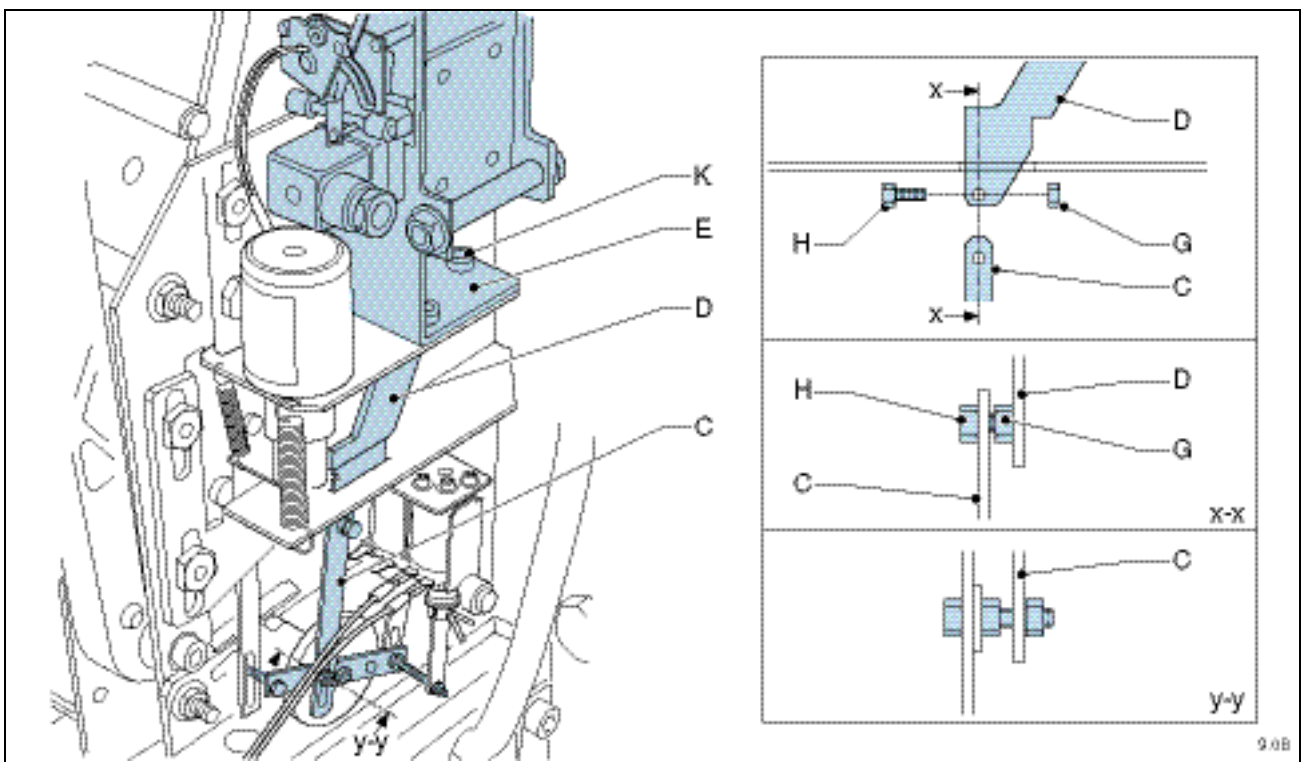

- Set the delay of the undervoltage coil.
 - Turn the handle (fig. 9.09A) to the left or to the right.
Handle fully left: no delay.
Handle fully right: delay of 3 or 4 seconds.
- Electrically connect the undervoltage coil according to the diagram delivered.
- Check the operation of the undervoltage coil.

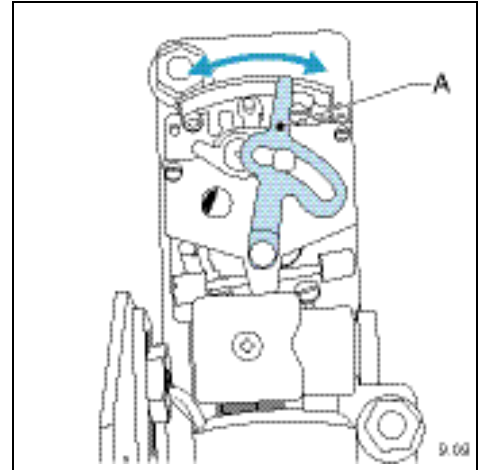

9.4.4 Mounting kit base plate

This kit is only required if not present in the basic equipment.

Order number mounting kit: OP307070 consists of:

order number	description	number	pos. no.
VO212527	VO base plate VA-2	1	
VA457154	Blank connection mech. mechanical drive shaft in VA-2	1	fig. 9.10 A
GR040988	Flange bolt M8x20 Ripp	2	fig. 9.10 B
GR041308	Nut with collar Ripp CL10 M8	1	fig. 9.10 C
GR041105	Lock nut nylon ring DIN 985 M5	2	fig. 9.10 D
GR071958	Schnorr locking cup spring M8	1	fig. 9.10 E
GR040192	Low round headed screw ISO 7380 M8x20	1	fig 9.10 F

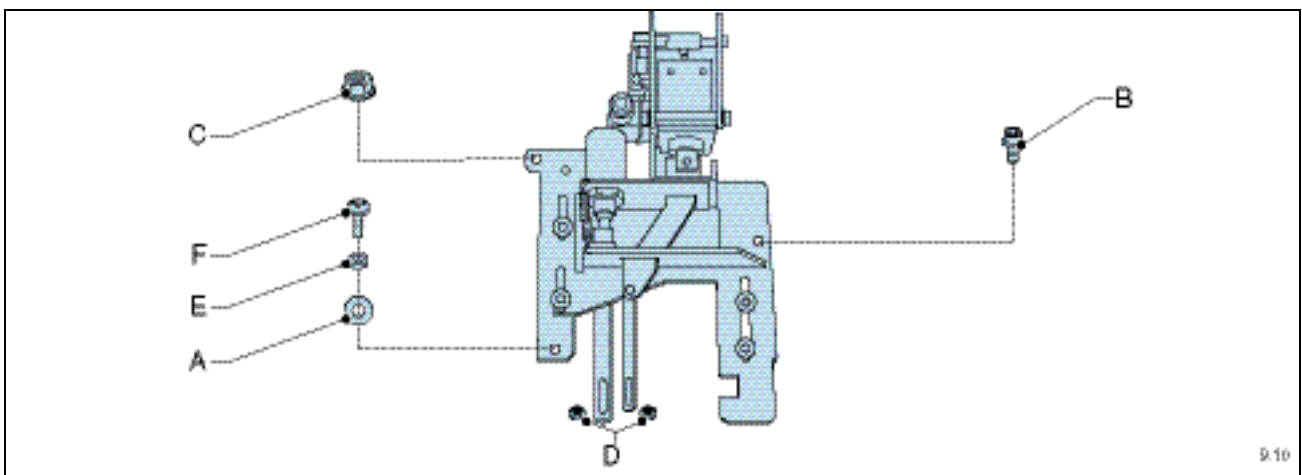

9.4.5 Mounting instructions for the base support

- Slide the base plate over the free top left end and there mount the M8 nut. The blank is positioned as connecting piece on the right above the M8 bolt, on the left underneath the round headed screw and Schnorr Ø M8 and behind the base plate .
- Dismount the M4 nut from the undervoltage coil (see for this the mounting instructions of the undervoltage coil) and the M4 nut for the damper strip.
- Place the strips over the M4 bolts that have become free and remount the M4 nuts.
- Tighten the M4 nuts until they are three millimetres away from the top of the bolt.



The strip of the undervoltage coil is slid over the threaded end along the front side.



The damper strip is slid backwards over the threaded end.

9.4.6 Final check and commissioning

The following activities must always be carried out after mounting the undervoltage coil.

- Check that the fitting materials are properly attached.
- Electrically connect the undervoltage coil according to the diagram.
- Test the undervoltage coil circuit using a multimeter. If the undervoltage coil is supplied by an external power source, an auxiliary contact must always be installed.
- Mount the cover of the VA-2 (RP).
- Put the entire medium voltage switchgear and the circuit breaker into operation.

9.5 Key locks

A key lock can be attached to a mechanical drive in the form of a Ronis lock. The Ronis lock prevents the laying in of the circuit breaker. In this way an adequate protection against unintentionally switching on the circuit breaker is created.

9.5.1 Preparation for mounting

The following preparations must always be made **before** starting to mount the Ronis lock:

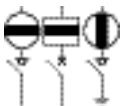

- Make the entire medium voltage switchgear and the circuit breaker voltage free.
- On the concerned cubicle, open both the load-break switch and the circuit breakers.
- The HV cable connection side must also be voltage free.
- Close the earthing switch of the medium voltage switchgear.

- Remove the door of the medium voltage switchgear.
- Dismount the cover from the VA-2 (RP).
 - Unscrew the two (fig. 9.01A) screws.
 - Remove the two screws with their PVC rings (fig. 9.01B).
 - Remove the cover.

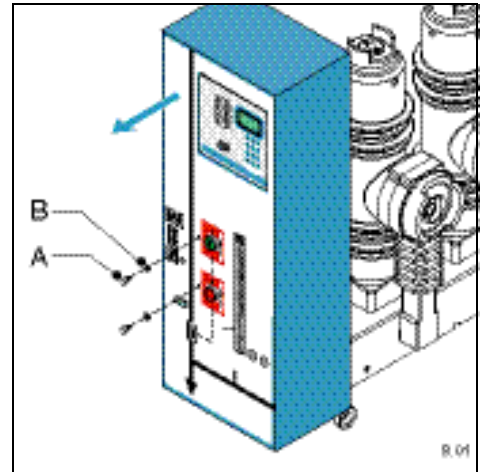

9.5.2 Mounting the key lock - general

A special mounting kit DF000067 is available for mounting the key lock.

Order number mounting kit: DF000067 consists of:

order number	description	number	pos. no.
OP100000	Ronis lock 1 cylinder incl. key	1	fig. 9.11 A
VA407317	Connecting strip Ronis switching-on shaft GV	1	fig. 9.11 B
VA407318	Locking lever Ronis VA-2 GV	1	fig. 9.11 C
VA427036	Montageplaat Ronis GV	1	fig. 9.11 D
VA427036	Mounting plate Ronis GV	1	fig. 9.11 D
VE040036	Spring catch knife	1	fig. 9.11 E
GR040922	Cylindrical screw DIN 912 M5x25 full thread	2	fig. 9.11 F
GR041005	Hexagon nut DIN 934 M5	1	fig. 9.11 G
GR071956	Schnorr locking cup spring Ø M6	2	fig. 9.11 H
GR040929	Cylindrical screw DIN 912 M6x16 full thread	3	fig. 9.11 I
GR041306	Nut with collar RIPP CL10 M6	3	fig. 9.11 J
GR040707	Countersunk screw DIN 7991 M5x35	4	fig. 9.11 L
OP402100	Two auxiliary contact R/PL2/shaft	1	
GR041105	Lock nut nylon ring DIN 985 M5	4	fig. 9.11 M
GR041108	Lock nut nylon ring DIN 985 M8	1	fig. 9.11 N
GR041505	Flat washer DIN 125 M5	1	fig. 9.11 O

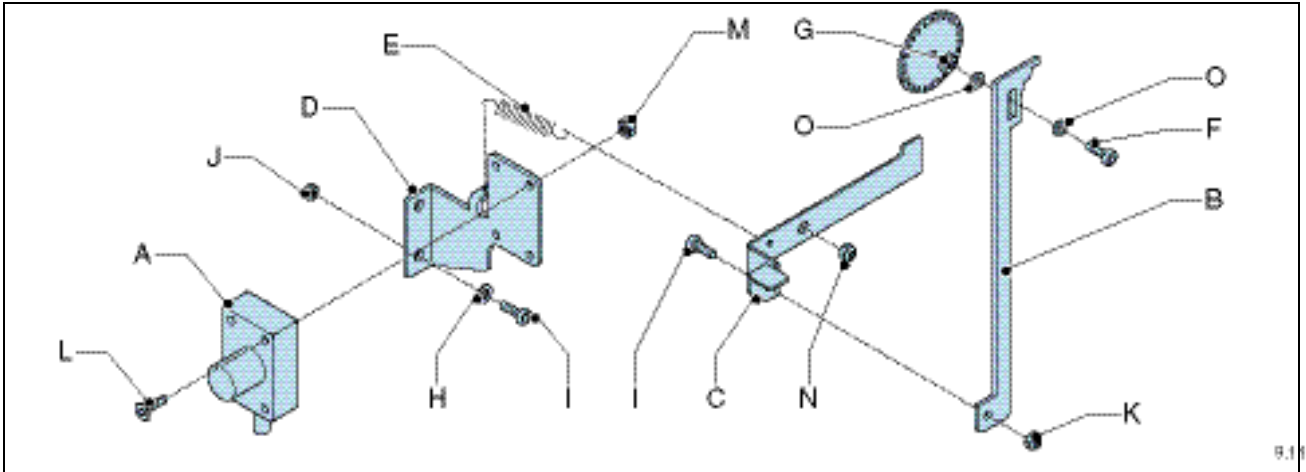

9.5.3 Mounting instructions for the base support:

- Mount the support VA427036 (D) as indicated in the drawing with the cylindrical screws, locking cup spring and the RIPP bolts (J, H and I).
- Mount the Ronis lock on the positioned support using the countersunk screws and the lock nuts (L and M).
- Mount the locking lever (C) using the lock nut M8.
- Mount the locking lever (C) together with the connecting strip (B) using a cylindrical screw and the lock nut (I and K).
- Hook the spring (E) between two pieces as indicated in the drawing.
- Mount the fastening material in the upper part of the white disc as indicated in fig. 9.12. There must be two millimetres of clearance between the nut and the connecting strip. This can be obtained by adjusting the nut in relation to the bolt and blocking it.
- The bolt in the white disc does not come through on the back side of the disc. There is one hole difference between line x and the bolt.

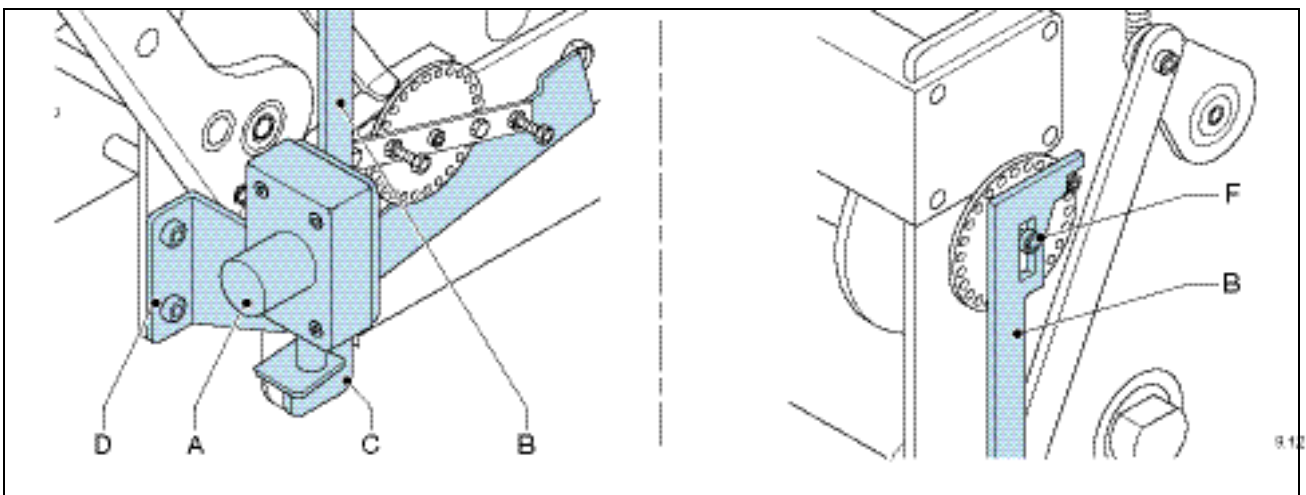

9.5.4 Final check and commissioning

The following activities must always be carried out after mounting the key lock.

- Check that the fitting materials are properly attached.
- Check the operation of the key lock.

9.6 Auxiliary contacts

Auxiliary contacts can be mounted on the mechanical drive mechanism and always have an indicating function. There is room for placing up to 10 NO + 10 NC for the following indicating functions, including:

- The position of the circuit breaker: IN or OUT
- The closing and trip coil
- Automatic switching on again
- Other indications (e.g. optical signal, acoustic signal)

9.6.1 Preparation for mounting

The following preparations must always be made **before** starting to mount one or more auxiliary contacts:

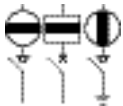

- Make the entire medium voltage switchgear and the circuit breaker voltage free.
- On the concerned cubicle, open both the load-break switch and the circuit breakers.
- The HV cable connection side must also be voltage free.
- Close the earthing switch of the medium voltage switchgear.
- Remove the door of the medium voltage switchgear.
- Dismount the cover from the VA-2 (RP).
 - Unscrew the two (fig. 9.01A) screws.
 - Remove the two screws with their PVC rings (fig. 9.01B).
 - Remove the cover.

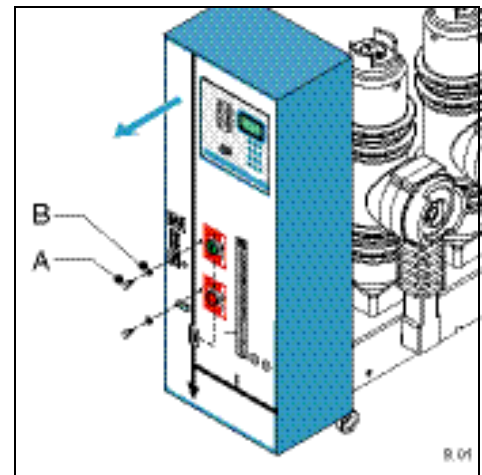

9.6.2 Mounting the auxiliary contacts - general

Mounting kits are available for mounting the auxiliary contacts. The composition of these mounting kits depends on the required number of auxiliary contacts.

Mounting kits available for the auxiliary contacts are:

order number	description
VA000056	Auxiliary contact tensioned spring 1NO/1NC on VA-2/VA-2RP
VA000057	Auxiliary contact tensioned spring 2NO/2NC on VA-2/VA-2RP
VA000058	Auxiliary contact tensioned spring 3NO/3NC on VA-2/VA-2RP
VA000041	Auxiliary contact 1NO/1NC on VA-2/VA2-RP
VA000042	Auxiliary contact 2NO/2NC on VA-2/VA2-RP
VA000043	Auxiliary contact 3NO/3NC on VA-2/VA2-RP
VA000044	Auxiliary contact 4NO/4NC on VA-2/VA2-RP
VA000045	Auxiliary contact 5NO/5NC on VA-2/VA2-RP
VA000046	Auxiliary contact 6NO/6NC on VA-2/VA2-RP
VA000047	Auxiliary contact 7NO/7NC on VA-2/VA2-RP

order number	description
VA000048	Auxiliary contact 8NO/8NC on VA-2/VA2-RP
VA000049	Auxiliary contact 9NO/9NC on VA-2/VA2-RP
VA000050	Auxiliary contact 10NO/10NC on VA-2/VA2-RP

9.6.3 Mounting the auxiliary contacts - mounting kit

The following kit is required for mounting each auxiliary contact. The numbers of the parts shall be multiplied in proportion to the number of auxiliary contacts required:

Order number mounting kit VA00004X or VA000050 consists of:

order number	description	number	pos. no.
GR013433	Blind rivet 3.2x8 DIN7337A	2	fig. 9.13 A
OP626603	Auxiliary contact Shaltbau wheel	1	fig. 9.13 B

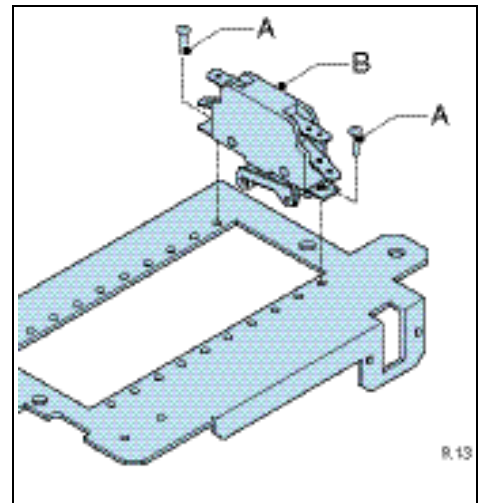

9.6.4 Mounting instructions for the base support

- Position the auxiliary contact (B) on the desired place and mount the auxiliary contact using blind rivets (A).
- Connect the auxiliary contact according to the electric diagram.

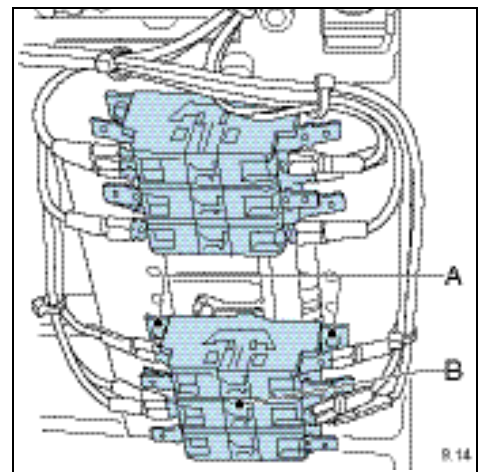

9.6.5 Final check and commissioning

Order number mounting kit VA00005x consists of:

order number	description	number	pos. no.
GR013433	Blind rivet 3.2x8 DIN7337A	2	fig. 9.14 A
OP626603	Auxiliary contact Shaltbau wheel	1	fig. 9.14 B

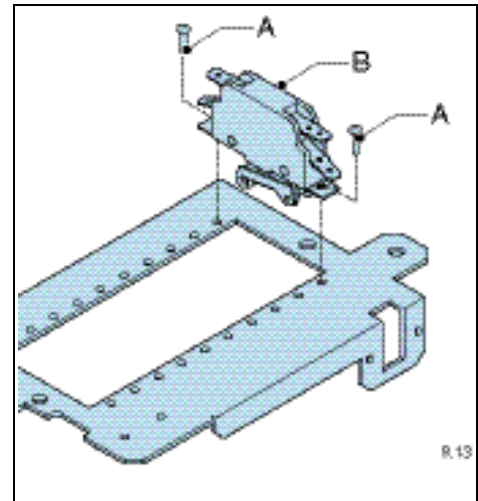

9.6.6 Mounting instructions for auxiliary contacts of armed spring

- Place the auxiliary contact (B) on the desired place and assemble the auxiliary contact using blind rivets (A).
- Connect the auxiliary contact according to the wiring diagram

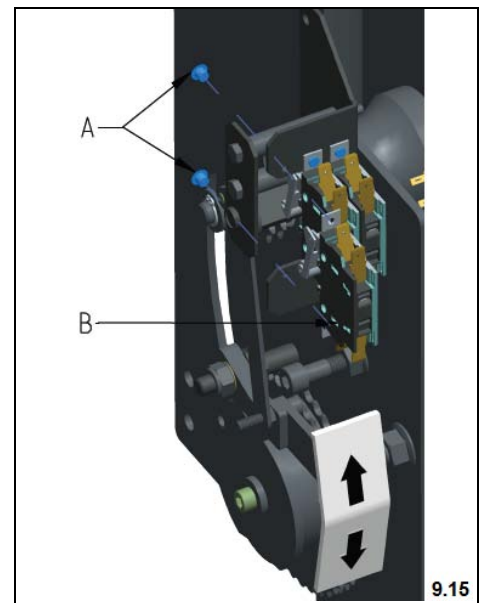

9.6.7 Final check and commissioning

The following actions must always be carried out after mounting the auxiliary contacts:

- Check that the fitting materials are properly attached.
- Test the auxiliary contacts circuit, in the closed as well as in the open position, using a multimeter.
- Connect the auxiliary contacts electronically using the plug connections according to the supplied wiring diagram.
- Mount the cover of the VA-2 (RP).
- Commission the entire medium voltage switchgear and the circuit breaker.

